

**ROTINA 380
ROTINA 380 R**



Repair instructions

Andreas Hettich GmbH & Co. KG
Föhrenstraße 12, D-78532 Tuttlingen / Germany
Phone (07461) 705-0
Fax (07461) 705-125
info@hettichlab.com, service@hettichlab.com
www.hettichlab.com

© 2008 by Andreas Hettich GmbH & Co. KG

All rights reserved. No part of this publication may be reproduced without the prior written permission of the copyright owner.

Modifications reserved!

AR1701EN / 11.08

Contents

1	Introduction	6
2	Symbol meanings.....	6
3	Disposal	7
4	Description of the centrifuge.....	8
4.1	Block diagram of the control.....	8
4.2	Operating panel (A2).....	9
4.3	Electronics ROTINA 380 (A1) resp. ROTINA 380 R (A1).....	9
4.4	Special features	10
4.5	Brake resistor (R1).....	10
4.6	Motor (M1) / Tacho system (B4, B2.1)	10
4.7	Imbalance sensor (B2.2).....	11
4.8	Motor-driven lid lock (A3)	11
4.9	Cooling system.....	11
4.10	Safety devices.....	12
5	Troubleshooting procedures.....	12
6	Error messages.....	13
6.1	Perform a MAINS RESET	13
6.2	Brief description	13
6.3	Description and elimination of errors.....	16
7	Settings and interrogations.....	36
7.1	Summary of the possible settings and interrogations.....	36
7.2	Inquiry the system information	37
7.3	Inquire and change the operating hours and inquire the number of the centrifugation runs.....	38
7.4	Set the acoustic signal	39
7.5	Set the centrifugation data displayed after switch-on.....	41
7.6	Set the functions Ramp Unit, RCF-Integral, B-Ramp and Multi programs	42
7.7	Set the address of the centrifuge	42
7.8	Logging the occurred faults.....	43
7.9	Logging of certain procedures (events).....	46
7.10	Speed values during the centrifugation run.....	48
7.11	Check both speed sensors.....	49
7.12	Set the centrifuge model	50

7.13	Blank the centrifuge model in the display	51
7.14	Cooling parameters	52
7.14.1	Set the temperature unit	52
7.14.2	Inquire the temperature values	53
7.14.3	Deactivate the temperature sensor (B2) at the top of the centrifuge chamber	55
7.14.4	Compensate the temperature sensors	56
7.15	Imbalance values	58
7.15.1	Logging the maximum imbalance values	58
7.15.2	Inquiry the current and the maximum imbalance values	59
7.15.3	Setting the imbalance switch-off	60
7.16	Set the transmission rate (baud rate) of the serial interface	62
7.17	Function test	63
7.18	Delete programs and program linking	69
7.19	Display the contents of the memory cells of the EEPROM	70
7.20	Initialise the EEPROM	71
7.21	Automatic repetition of the centrifugation run	72
8	Update the software of the control processor	74
8.1	Install the flash-program on the PC	74
8.2	Perform a software update	74
9	Functional check after a repair	76
10	General arrangement of the components	77
11	Mounting and removing components	81
11.1	Removing the front panel	81
11.2	Removing the support sheet of the electronics (A1)	81
11.3	Hook in the front panel at the support sheet for electronics (A1)	82
11.4	Removing the upper part of the centrifuge housing	82
11.5	Removing Motor (M1) / Rubber-metal bearings / Speed sensor (B2.1, at the bottom of the motor) / Imbalance sensor (B2.2)	83
11.6	Speed sensor (B4, on top of the motor)	83
11.7	Motor-driven lid lock	84
11.7.1	Removing the motor-driven lid lock	84
11.7.2	Replacing the left lid lock	84
11.7.3	Replacing the right lid lock	84
11.7.4	Replacing the eccentric disc	85
11.7.5	Replacing the sliding blocks	85

11.8	Electronics (A1).....	86
11.9	Operating panel (A2).....	86
11.10	Rotary encoder (S1).....	87
11.11	Brake resistor (R1) with overtemperature switch.....	87
11.12	Temperature sensor (B1) at the bottom of the centrifuge chamber (only in centrifuges with cooling).....	87
11.13	Temperature sensor (B3) at the condenser (only in centrifuges with cooling).....	88
11.14	Fan (M3) at the condenser (only in centrifuges with cooling).....	88
11.15	Fan (M5) for cooling the electronics (only in centrifuges with cooling).....	88
11.16	Starting capacitor / starting relay (only in centrifuges with cooling).....	89
11.17	Mains switch (F1).....	89
11.18	Appliance plug (A4 resp. A5).....	89
11.19	Transformer (T1, only in 120 V version).....	90
11.20	Circuit breaker (F2, only in 120 V version).....	90
11.21	Packing ring.....	90
11.22	Pneumatic spring.....	91
12	Technical documents.....	92
12.1	Tachometer code configuration of the rotors.....	92
12.2	Cooling diagram.....	93
12.3	Connecting diagram.....	95
12.3.1	Abbreviations of the cable colours.....	95
12.3.2	Connecting diagram ROTINA 380 / 380 R.....	96
12.4	Technical specifications.....	98

1 Introduction

- Repairs must only be carried out by personnel authorised to do so by the manufacturer.



Interventions and modifications at centrifuges, which have been conducted by persons not authorized by the Andreas Hettich GmbH & Co. KG company, are at their own risk and entail the loss of all guarantee and liability claims. In such an event any guarantee claim or liability claim against the Andreas Hettich GmbH & Co. KG company expires.

- Only original spare parts and original accessories licensed by the Andreas Hettich GmbH & Co. KG company are allowed to be utilised.



If no original spare parts or no original accessories are used, any guarantee claim or liability claim against the Andreas Hettich GmbH & Co. KG company ceases to exist.

- Information about the operation of the centrifuge please see operating instructions.
- We reserve all rights for these technical documents.

2 Symbol meanings



Symbol on the machine:

Attention, general hazard area.

Before using the centrifuge implicitly read the operating instructions and pay attention to the safety relevant references!



Symbol in this document:

Attention, general hazard area.

This symbol refers to safety relevant warnings and indicates possibly dangerous situations.

The non-adherence to these warnings can lead to material damage and injury to personal.



Symbol in this document:

Warning! Danger for human lives by electric shock.



Symbol on the machine and in this document:

Beware of hot surface.



Symbol on the machine and in this document:

Plastic suspension can only be used in temperatures up to a maximum of 40°C / 104°F.



Symbol on the machine:

Equipotential: Connector (PE connector) for potential equalization (only for centrifuge with PE connector).



Symbol in this document:

This symbol refers to important circumstances.



Symbol on the machine and in this document:

Symbol for the separate collection of electric and electronic devices according to the guideline 2002/96/EG (WEEE). The device belongs to Group 8 (medical devices).

Applies in the countries of the European Union, as well as in Norway and Switzerland.

3 Disposal

When you are disposing of the device, the respective statutory rules must be observed. Pursuant to guideline 2002/96/EC (WEEE), all devices supplied after August 13, 2005 may not be disposed as part of domestic waste. The device belongs to group 8 (medical devices) and is categorized in the business-to-business field.



The icon of the crossed-out trash can shows that the device may not be disposed as part of domestic waste.

The waste disposal guidelines of the individual EC countries might vary. If necessary, contact your supplier.

4 Description of the centrifuge

4.1 Block diagram of the control

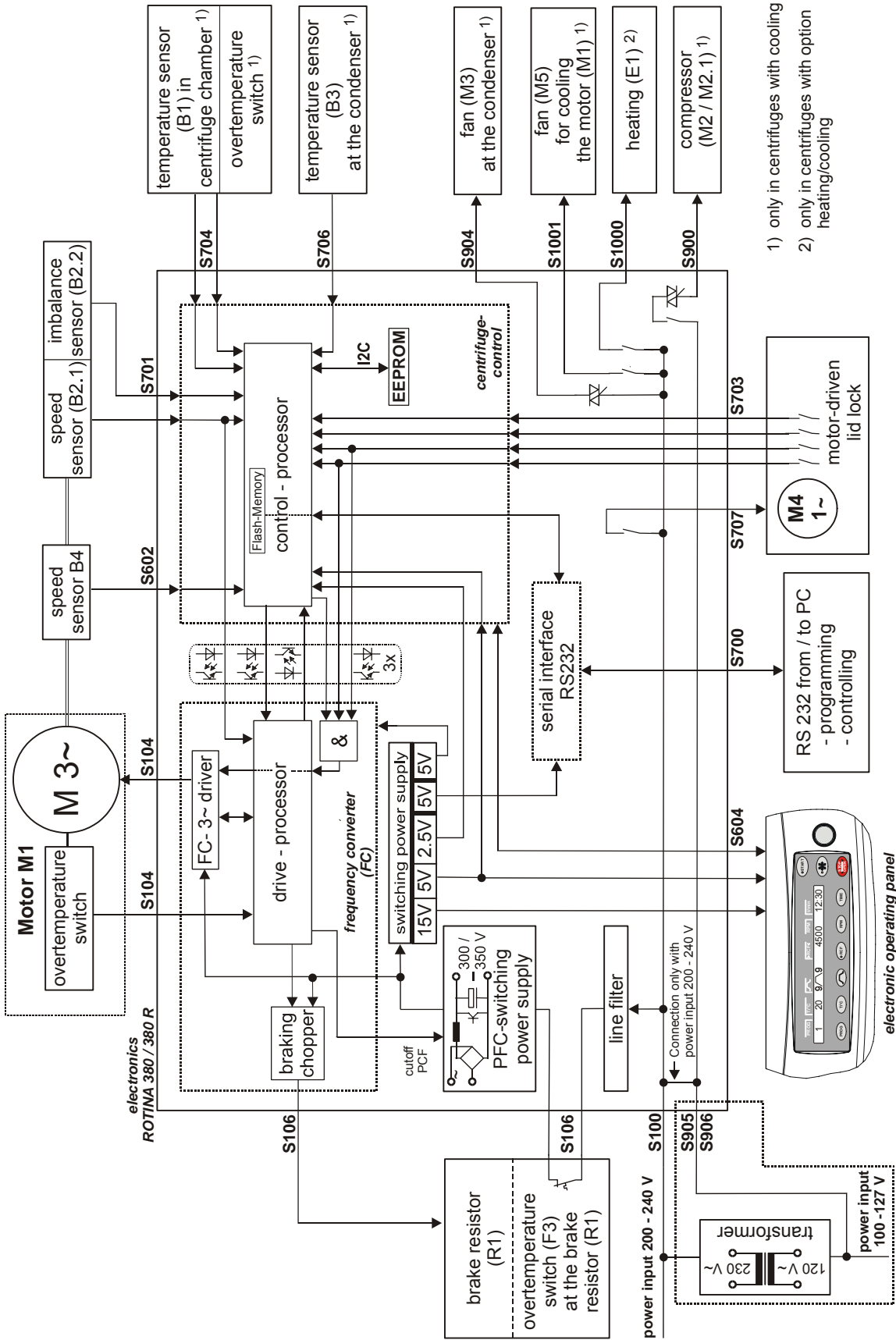

- Status indication with a green LED:
Standby: the green LED lights up
Centrifugation run: the green LED lights up
Case of error: the green LED flashes

If the drive-processor detects an error, it switches off the motor.

4.4 Special features

- Multiprocessor concept:
The control- and the drive-processor monitoring one another. If one processor stops working, the other processor switches off the drive.
- Interface concept:
The information transmission is monitored with an additional check sum.
- Hardware concept:
All safety related switches are break contacts. This also ensures that loose contacts and cable rupture can be detected.

4.5 Brake resistor (R1)

- An overtemperature switch (F3) protects the brake resistor (R1) against fire. If the braking chopper has a short circuit, the brake resistor becomes hot due to the high current, and the overtemperature switch (F3) disconnects the supply voltage of the centrifuge.

4.6 Motor (M1) / Tacho system (B4, B2.1)

- The motor (M1) is a three-phase asynchronous motor with four pairs of poles.
- A speed sensor (B4, speedometer) which is screwed onto the motor receives
 - the rotor code information and
 - the speed information (6 pulses per revolution)from the magnets of the tacho ring attached to the rotor.
- An additional speed sensor (B2.1, speedometer) is together with the imbalance sensor (B2.2) in one housing. This housing is screwed to the bottom of the motor. The speed signal (1 pulse per revolution) will be triggered by a magnet fixed at the motor axle. This signal is used for the release of the motor-driven lid lock.
- The Electronics (A1) monitors and regulates the speed.
 - Double safety: The drive-processor has been programmed in such a way that it switches off the drive when the speed is higher than the permissible rotor speed. Then error message "FU/CCI-ERROR 61.19 Overspeed" will be displayed.
- The Electronics (A1) monitors the rotor standstill.

4.7 Imbalance sensor (B2.2)

- An electronic sensor monitors the imbalance.
- The imbalance sensor (B2.2) and the speed sensor (B2.1) are together in one housing, screwed to the bottom of the motor (M1).
- Imbalance is detected only in running mode (run up, centrifuging and braking).
- If impermissible imbalance is detected, the drive switches off and the rotor slows down braked until it stops.

4.8 Motor-driven lid lock (A3)

- The lid can be opened only if the Electronics (A1) has detected rotor standstill.
- By pressing the key  the lid opens motor-driven.
- The motor locks the lid only if both lid brackets actuate both lid switches (Ll, Lr), the position switch (Mo) for position "lid opened" is actuated and the rotor has standstill.
- The centrifuge can only be started when the lid is closed.

4.9 Cooling system

- The cooling system is a hermetical system.
- The cooling system consists of the following components:
 - Compressor (M2, M2.1)
 - Cooling tubes around the centrifuge chamber (evaporator)
 - Condenser
 - Dryer
 - Fan (M3)
 - Temperature sensor T1 (B1) and overtemperature switch in the centrifuge chamber
 - Temperature sensor T3 (B3) on the condenser
- In the housing of the temperature sensor T1 (B1) also the overtemperature switch is included. With centrifuges with cooling the drive switches off, when the temperature is $> 60^{\circ}\text{C}$ / $> 140^{\circ}\text{F}$, and with option Heating/Cooling $> 120^{\circ}\text{C}$ / $> 248^{\circ}\text{F}$.
- The refrigerant will be cooled down with a fan (M3). The speed of the fan is controlled dependent to the temperature at the condenser.
- When opening the lid of the centrifuge, the cooling system switches off.
- When the rotor is at standstill and the lid is closed the centrifuge chamber will be cooled on the preselected temperature, if this is lower than 20°C / 68°F . During the standby-cooling the compressor is time-cycle controlled (2 minutes ON / 3 minutes OFF).

4.10 Safety devices

Mains switch	⇒ with thermal overload protection
Over voltage protection and radio interference suppression filter	⇒ on Electronics (A1)
Additional radio interference suppression filter	⇒ in mains input circuit (only with 4706-01)
Frequency converter	⇒ on Electronics (A1), electrically protected
Motor	⇒ Overtemperature switch (> 150 °C / > 302°F)
Centrifuge chamber	⇒ Overtemperature switch (> 60 °C / > 140°F, with option Heating/Cooling > 120°C / > 248°F)

5 Troubleshooting procedures

- Fuses in installation in which centrifuge is installed are intact.
- Supply voltage present at (see circuit diagram):
 - Connecting cable
 - Appliance plug
 - Mains switch
 - Electronics (A1), plug S100
- Look for the displayed error code in the chapter 6, pg. 13.
- Remedy the error according to the instructions.
- Carry out a functional check after every repair and whenever a component is replaced, see pg. 76, chapter 9.

6 Error messages

6.1 Perform a MAINS RESET

- Switch off the mains switch (switch position "0").
- Wait at least 10 seconds and then switch on the mains switch again (switch position "I").

6.2 Brief description

Error designation	No.	Brief description	Page
TACHO-ERROR	1	Speed sensor on top of the motor: Speedometer pulses break down during rotation	16
TACHO-ERROR	2	After start command no speedometer pulses from both speed sensors	17
IMBALANCE	(3)*	Imbalance on motor axle	18
CONTROL-ERROR	4.1	Lid lock error	18
CONTROL-ERROR	4.2	Lid lock error	19
CONTROL-ERROR	4.3	Lid lock error	19
CONTROL-ERROR	4.4	Lid lock error	19
CONTROL-ERROR	4.5	Lid lock error	20
N > MAX	5	Excessive speed error	20
CONTROL-ERROR	6	Lid lock error	21
ROTORCODE	10.1	No start code recognized	21
ROTORCODE	10.2	Invalid rotor code	21
ROTORCODE	10.3	Error during reading the rotor code	22
MAINS INTERRUPT	(11)*	Mains interruption.	22
VERSION ERROR	12	Incorrect machine type and/or cooling version	22
N < MIN	13	Speed error: slippage is too high	23
CONTROL-ERROR	22	Communication error I ² C bus	23
CONTROL-ERROR	25.1	EEPROM read error	23
CONTROL-ERROR	25.2	EEPROM write error	24
CONTROL-ERROR	25.3	EEPROM communication error	24
CONTROL-ERROR	25.4	EEPROM storage error	23

* Error number will not be displayed

Error designation	No.	Brief description	Page
SER I/O-ERROR	31	TIME OUT, communication error with frequency converter	24
SER I/O-ERROR	34	Communication error with frequency converter	24
SER I/O-ERROR	36	NAK, communication error with frequency converter	24
°C / *-ERROR	51	Overtemperature on condenser	24
°C / *-ERROR	52	Overtemperature in centrifuge chamber	25
°C / *-ERROR	53	Temperature sensor at the bottom of the centrifuge chamber is defective	25
°C / *-ERROR	54	Temperature sensor at the top of the centrifuge chamber is defective (not existing in ROTINA 380 R)	26
°C / *-ERROR	55	Temperature sensor on condenser is defective	26
FU/CCI-ERROR	60	Faulty release signal to frequency converter (drive-processor)	27
FU/CCI-ERROR	61.1	Undervolt, undervoltage frequency converter	27
FU/CCI-ERROR	61.2	Overvolt, overvoltage frequency converter	27
FU/CCI-ERROR	61.4	OverT FU, Übertemperatur frequency converter	28
FU/CCI-ERROR	61.5	OverT Mot, overtemperature in motor	28
FU/CCI-ERROR	61.9	Overl Peak, peak current error frequency converter	28
FU/CCI-ERROR	61.13	Short cir, short circuit cut-off frequency converter	29
FU/CCI-ERROR	61.16	FU Enable, no enabling for frequency converter	29
FU/CCI-ERROR	61.17	Communication error with control-processor	29
FU/CCI-ERROR	61.18	frequency converter receives wrong direction of rotation command	30
FU/CCI-ERROR	61.19	Overspeed, frequency converter recognizes excess speed	30
FU/CCI-ERROR	61.20	Faulty speed measurement of the frequency converter	30
FU/CCI-ERROR	61.128	Internal frequency converter error	31
FU/CCI-ERROR	61.129	System error of the frequency converter	31
FU/CCI-ERROR	61.130	Program memory of the frequency converter defective	31
FU/CCI-ERROR	61.131	Reset by Watchdog of the frequency converter	31

Error designation	No.	Brief description	Page
SENSOR-ERROR	90	No mains synchronisation	31
SENSOR-ERROR	91	Imbalance sensor – error (x-axis)	32
SENSOR-ERROR	92	Imbalance sensor – error (y-axis)	32
SENSOR-ERROR	93	Imbalance sensor - error: temperature sensor of the imbalance sensor defective	32
TACHO-ERROR	96	Speed sensor at the bottom of the motor: Speedometer pulses break down during centrifugation run	33
°C / *-ERROR	97	Temperature sensor on the Electronics defective	33
°C / *-ERROR	98	Temperature sensor on the Electronics detects overtemperature	33
PROGRAMM- ERROR	100	Check sum error with programs (Single programs)	34
MULTI PROG ERROR	101	Check sum error with program linking (Multi programs)	34
NO ROTOR OR ROTORCODE ERROR	---	No rotor installed or speed sensor on top of the motor defective	34
N > ROTOR MAX	---	Speed in the selected program greater than the maximum speed of the rotor (Nmax).	35
FC INIT ERROR	---	Initialisation of the frequency converter is faulty	35
FATAL EEPROM ERROR 1 – 5	---	EEPROM error	35

6.3 Description and elimination of errors



After occurrence of a fault the cooling / heating switches off. The standby cooling takes place after the rotor is at standstill and the lid is closed.

During a fault the lid can be opened after the rotor is at standstill.

TACHO - ERROR 1 wait 3:00

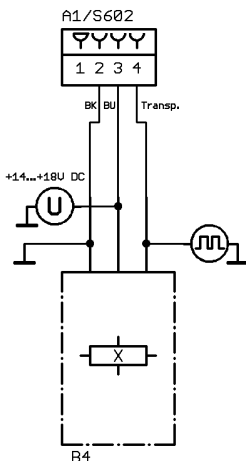

During centrifugation the speedometer pulses of the speed sensor (B4) on top of the motor are interrupted.

The rotor slows down braked until it stops.

No further user operation possible.

After the rotor is at standstill and the 3 minutes have elapsed the lid lock will be released and the lid can be opened.

- Reset error code:
 - Open the lid.
 - Switch off the mains switch (switch position "0").
 - Wait at least 10 seconds.
 - Turn the rotor vigorously by hand.
 - Switch on the mains switch again (switch position "1").
- The rotor must turn during switch-on.
- Speed sensor (B4) on top of the motor defective or loose contact on plug.
 - Check the function of the speed sensor (B4), see pg. 63, chapter 7.17, item 6.
 - Measure supply voltage on plug S602 / Electronics (A1) pin 2 – pin 3 (+14-18 VDC).
 - Measure speedometer pulses on plug S602 / Electronics (A1) pin 2 - pin 4 (signal).
- Electronics (A1) is defective.

TACHO - ERROR 2 wait 3:00

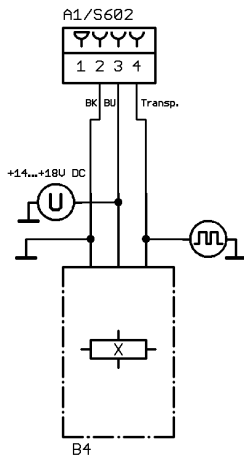

After start-up no speedometer pulses will be received from both speed sensors.

The rotor slows down braked until it stops.

No further user operation possible.

After the rotor is at standstill and the 3 minutes have elapsed the lid lock will be released and the lid can be opened.

- Reset error code:
 - Open the lid.
 - Switch off the mains switch (switch position "0").
 - Wait at least 10 seconds.
 - Turn the rotor vigorously by hand.
 - Switch on the mains switch again (switch position "1").
 - 👉 The rotor must turn during switch-on.

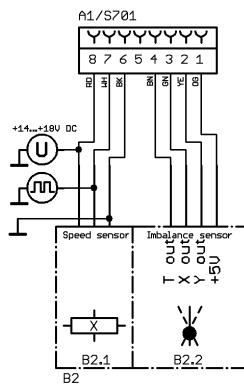

- Motor is blocked or defective.
- Loose contact on motor plug S104.
- Both speed sensors (B4, B2.1) defective or loose contact on plug.
 - Check the function of the speed sensors, see pg. 63, chapter 7.17, item 6.
 - Speed sensor (B4) on top of the motor:
 - Measure supply voltage on plug S602 / Electronics (A1) pin 2 – pin 3 (+14-18 VDC).
 - Measure speedometer pulses on plug S602 / Electronics (A1) pin 2 - pin 4 (signal).
 - Speed sensor (B2.1) at the bottom of the motor:
 - Measure supply voltage on plug S701 / Electronics (A1) pin 6 – pin 8 (+14-18 VDC).
 - Measure speedometer pulses on plug S701 / Electronics (A1) pin 6 - pin 7 (signal).
- Electronics (A1) is defective.

IMBALANCE

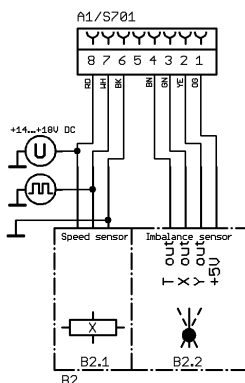

Imbalance on motor axle.

The rotor slows down braked until it stops.

- Reset error code:
Open the lid or perform a MAINS RESET.
- Weight difference in rotor components.
- The supporting lugs of the rotor are not lubricated.
- Check grounding of the motor.



A missing grounding of the motor causes disturbing signals which can produce the error.

- Check the maximum permissible imbalance values, see pg. 60, chapter 7.15.3.
- Imbalance sensor (B2.2) is defective.
Measure supply voltage on plug S701 / Electronics (A1) pin 6 – pin 1 (+5 VDC).
Measure on Electronics (A1) / plug S701, pin 6 – pin 2 and pin 6 – pin 3 (square wave signal 5 V /100 Hz).
- Electronics (A1) is defective.

CONTROL - ERROR 4.1

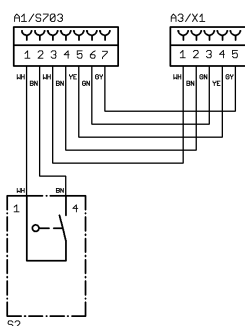

The lid switches for the left and/or right hook have opened during the centrifugation run.

The rotor slows down without braking until it stops.

No further user operation possible except opening the lid.

- Reset error code:
After the rotor has stopped perform a MAINS RESET. If the left LED in the button **STOP / OPEN** is blinking after turning the centrifuge on again, press this button so that the motor-driven lid locking once again assumes the normal position (opened).
- An emergency unlocking was performed during the centrifugation run.
- Switches of the lid lock defective.
Check the function of both switches, see pg. 63, chapter 7.17, item 21.
Pull out plug S703 and check the function of the switches at the plug of the cable between pin 1 - pin 2 (left hook) and pin 3 - pin 4 (right hook).
- Electronics (A1) is defective.

CONTROL - ERROR 4.2

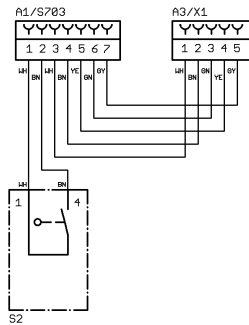

Error during testing the lid switches after the start command.

No further user operation possible except opening the lid.

- Reset error code:
Perform a MAINS RESET.
- Switches of the lid lock defective.
Check the function of both switches, see pg. 63, chapter 7.17, item 21.
Pull out plug S703 and check the function of the switches at the plug of the cable between pin 1 - pin 2 (left hook) and pin 3 - pin 4 (right hook).
- Electronics (A1) is defective.

CONTROL - ERROR 4.3

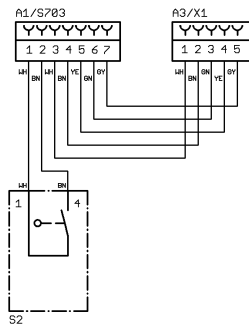

Position switch "Mc" of the motor-driven lid lock opens during the centrifugation run.

The rotor slows down braked until it stops.

No further user operation possible except opening the lid.

- Reset error code:
Perform a MAINS RESET.
- Position switch "Mc" defective.
Check the function of the switch, see pg. 63, chapter 7.17, item 21.
Pull out plug S703 and check the function of the switch at the plug of the cable between pin 6 - pin 7 (position switch "Mc").
- Electronics (A1) is defective.

CONTROL - ERROR 4.4

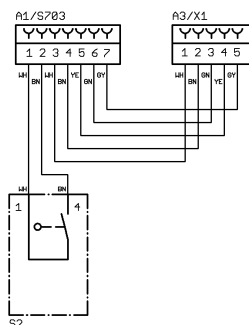

The lid can not be locked by motor.

No further user operation possible.

- Reset error code:
Perform a MAINS RESET.
- After opening the lid one of the two lid switches (for the hooks) remains closed.
- Switches of the lid lock defective.
Check the function of both switches, see pg. 63, chapter 7.17, item 21.
Pull out plug S703 and check the function of the switches at the plug of the cable between pin 1 - pin 2 (left hook) and pin 3 - pin 4 (right hook).
- Electronics (A1) is defective.

CONTROL - ERROR 4.5

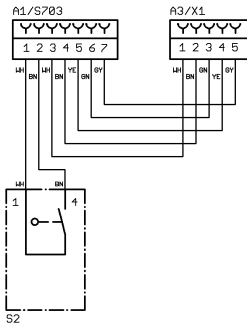

Position switch "Mo" of the motor-driven lid lock closes during the centrifugation run.

The rotor slows down braked until it stops.

No further user operation possible except opening the lid.

- Reset error code:
Perform a MAINS RESET.
- Position switch "Mo" defective.
Check the function of the switch, see pg. 63, chapter 7.17, item 21.
Pull out plug S703 and check the function of the switch at the plug of the cable between pin 5 - pin 7 (position switch "Mo").
- Electronics (A1) is defective.

N > MAX 5

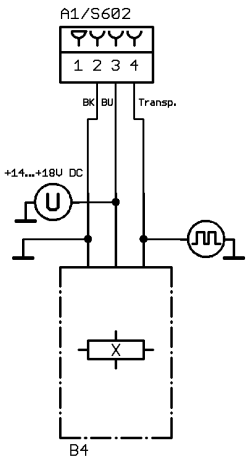

Excess speed. The speed measured by the speed sensors B4 or B2.1 is 250 RPM higher than the maximum speed of the rotor.

The rotor slows down braked until it stops.

No further user operation possible except opening the lid.

- Reset error code:
Perform a MAINS RESET.
- Both speed sensors (B4, B2.1) defective or loose contact on plug.
 - Check the function of the speed sensors, see chapter "7.17, item 6".
 - Speed sensor (B4) on top of the motor:
Measure supply voltage on plug S602 / Electronics (A1) pin 2 – pin 3 (+14-18 VDC).
Measure speedometer pulses on plug S602 / Electronics (A1) pin 2 - pin 4 (signal).
 - Speed sensor (B2.1) at the bottom of the motor:
Measure supply voltage on plug S701 / Electronics (A1) pin 6 – pin 8 (+14-18 VDC).
Measure speedometer pulses on plug S701 / Electronics (A1) pin 6 - pin 7 (signal).
- Electronics (A1) is defective.

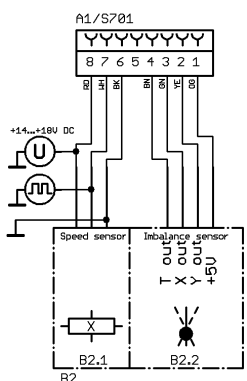

CONTROL - ERROR 6

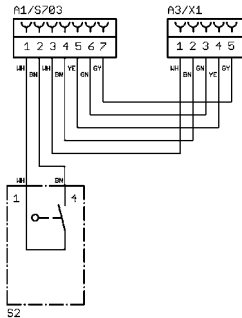

Lid lock error.

No further user operation possible except opening the lid.

- Reset error code:
Perform a MAINS RESET.
- The motor of the lid lock runs too slowly or it is blocked. The position switch "Mc" or "Mo" must close within 5 seconds.
- Position switch "Mc" or "Mo" defective.
Check the function of the switch "Mc" or "Mo", see pg. 63, chapter 7.17, item 21.
Pull out plug S703 and check the function of the switch at the plug of the cable between pin 6 - pin 7 (position switch "Mc") and between pin 5 - pin 7 (position switch "Mo").
- Electronics (A1) is defective.

ROTORCODE 10.1

Start code of the rotor coding not recognized.

The rotor slows down braked until it stops.

No further user operation possible except opening the lid.

- Reset error code:
Perform a MAINS RESET.
- Magnetic code on the rotor is defective, see pg. 92, chapter 12.1.
- Electronics (A1) is defective.

ROTORCODE 10.2

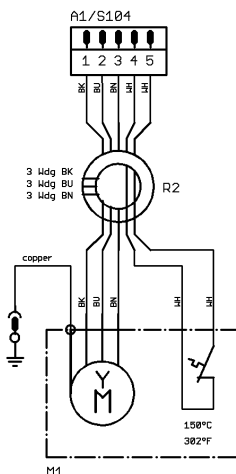

E2753 (220V) = 2,1 ohms between 2 motorwires
at cold motor ca. +15...30°C
at cold motor ca. +59°F...86°F

An invalid rotor code was read in during start-up.

The rotor slows down braked until it stops.

No further user operation possible except opening the lid.

- Reset error code:
Perform a MAINS RESET.
- Magnetic code on the rotor is defective, see pg. 92, chapter 12.1.
- Motor turns in false direction. Check the motor cables on plug S104 / Electronics (A1).
- Electronics (A1) is defective.

ROTORCODE 10.3

Error during reading the rotor code.

The rotor slows down braked until it stops.

No further user operation possible except opening the lid.

- Reset error code:
Perform a MAINS RESET.
- Magnetic code on the rotor is defective, see pg. 92, chapter 12.1.
- Electronics (A1) is defective.

MAINS INTERRUPT

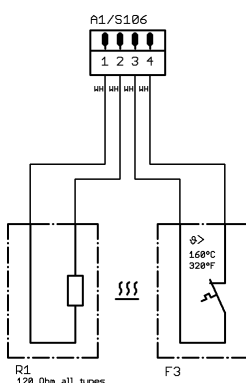

Interruption of mains supply during centrifugation.

During the interruption of the mains supply the rotor slows down without braking until it stops.

After the interruption of the mains supply the rotor slows down braked until it stops.

- Reset error code:
Open the lid and press the **START / IMPULS** key.



The error code **cannot** be reset by a MAINS RESET.

- Power failure.
- Overtemperature switch (F3) on the brake resistor (R1) has opened or is defective.
- Loose contact in the electrical wiring.
- Electronics (A1) is defective.

VERSION ERROR 12

Incorrect machine type and/or cooling version identified.

No further user operation possible except opening the lid.

- Perform an initialisation of the EEPROM, see chapter "7.20".
Then check the machine type and the cooling version (display after MAINS RESET).
- The installed electronics (A1) does not fit to the centrifuge model.
- Electronics (A1) is defective.

N < MIN 13

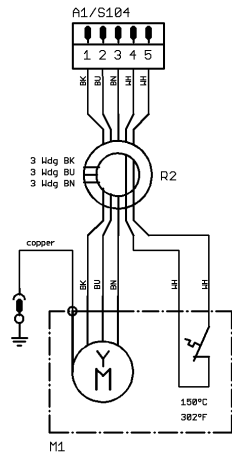

E2753 (2200) = 2,1 ohms between 2 motorwires
at cold motor ca. +15...30°C
at cold motor ca. +55°F...86°F

Insufficient speed, motor slippage is too high.

This error is displayed if the rotor speed (ACTUAL speed) is longer as 30 seconds lower than the SET speed.

The rotor slows down braked until it stops.

No further user operation possible except opening the lid.

- Reset error code:
Perform a MAINS RESET.
- Motor is labouring (damage to bearings).
- Motor has a short-circuited coil (coil is defective).
- Loose contact in the electrical connections.
- Electronics (A1) is defective.

CONTROL - ERROR 22

Communication error I²C bus.

The rotor slows down braked until it stops.

No further user operation possible except opening the lid.

- Reset error code:
Perform a MAINS RESET.
- Electronics (A1) is defective.

CONTROL - ERROR 25.1, 25.4

EEPROM: Read or storage error.

The rotor slows down braked until it stops.

No further user operation possible except opening the lid.

- Reset error code:
Perform a MAINS RESET.
- Delete the programs and the program linking, see pg. 69, chapter 7.18.
- Initialise the EEPROM, see pg. 71, chapter 7.20.
- Electronics (A1) is defective.

CONTROL - ERROR 25.2, 25.3

EEPROM: Write or communication error.

The rotor slows down braked until it stops.

No further user operation possible except opening the lid.

- Reset error code:
Perform a MAINS RESET.
- Electronics (A1) is defective.

SER I/O - ERROR 31, 34, 36

Communication error with the frequency converter.

The rotor slows down without braking until it stops.

No further user operation possible except opening the lid.

- Reset error code:
Perform a MAINS RESET.
- Electronics (A1) is defective.

°C / * -ERROR 51

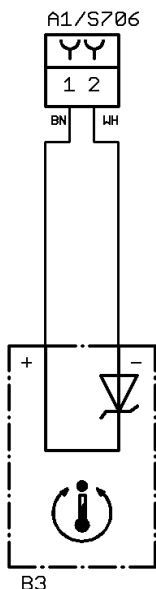

Overtemperature on condenser

The rotor slows down braked until it stops.

No further user operation possible except opening the lid.

- Reset error code:
Perform a MAINS RESET.
- Temperature on condenser $\geq 58^{\circ}\text{C}$ / 136°F .
- The temperature sensor (B3) on the condenser is defective.
Measure on Electronics (A1) / plug S706, pin 1 – pin 2.
Voltage $> 3.31\text{ V}$ = Temperature on condenser $> 58^{\circ}\text{C}$ / 136°F
Voltage at 25°C / 77°F = 2.98 V ($\pm 20\text{ mV}$)
A temperature change of 1°K causes a voltage change of 10 mV .
- Electronics (A1) is defective.
- Fan (M3) is defective.

°C / * -ERROR 52

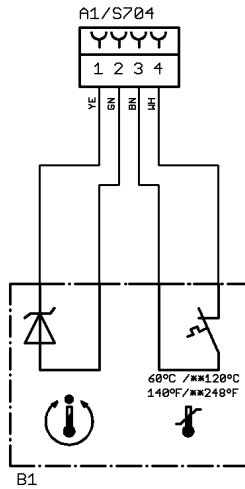

Overtemperature in centrifuge chamber

The rotor slows down braked until it stops.

No further user operation possible except opening the lid.

- Reset error code:
Perform a MAINS RESET.
- Temperature in centrifuge chamber > 60°C / 140°F, with option heating/cooling > 120°C / 248°F.
- Overtemperature switch in centrifuge chamber is defective.
Measure on Electronics (A1) / plug S704, pin 3 – pin 4
Switch closed: 0 VDC
Switch opened: +15 VDC
- Electronics (A1) is defective.
- Cooling is defective.

°C / * -ERROR 53

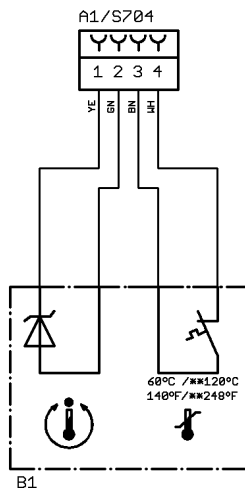

The temperature in the centrifuge chamber measured by the temperature sensor (B1) is out of the valid range.

The rotor slows down braked until it stops.

No further user operation possible except opening the lid.

- Reset error code:
Perform a MAINS RESET.
- The temperature sensor (B1) in the centrifuge chamber is defective.
Measure on Electronics (A1) / plug S704, pin 1 – pin 2.
Valid voltage range: 2,24 V up to 3,92 V.
Voltage < 0.5 V = short circuit
Voltage > 4.5 V = disruption
Voltage at 25°C / 77°F = 2.98 V (± 20 mV)
A temperature change of 1°K causes a voltage change of 10 mV.
- Electronics (A1) is defective.

°C / * -ERROR 54

The temperature in the centrifuge chamber measured by the temperature sensor (B2) is out of the valid range. The temperature sensor (B2) does not exist in the ROTINA 380 R.

 If the temperature sensor B2 (= T2) is activated in the "Select Menu", °C / * -ERROR 54 will be displayed.

No further user operation possible except opening the lid.

- Reset error code:
Perform a MAINS RESET.
- Deactivate the temperature sensor B2 (= T2) in the "Select Menu", see pg. 55, chapter 7.14.3.
- Electronics (A1) is defective.

°C / * -ERROR 55

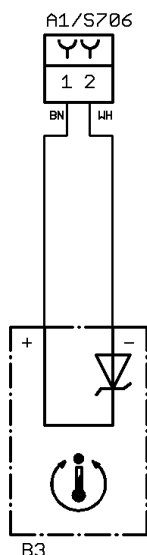

The temperature on the condenser measured by the temperature sensor (B3) is out of the valid range.

The rotor slows down braked until it stops.

No further user operation possible except opening the lid.

- Reset error code:
Perform a MAINS RESET.
- The temperature sensor (B3) on the condenser is defective.
Measure on Electronics (A1) / plug S706, pin 1 – pin 2.
Valid voltage range: 2,24 V up to 3,92 V.
Voltage < 0.5 V = short circuit
Voltage > 4.5 V = disruption
Voltage at 25°C / 77°F = 2.98 V (±20 mV)
A temperature change of 1°K causes a voltage change of 10 mV.
- Electronics (A1) is defective.

General notes for FU/CCI-ERROR 60 to FU/CCI-ERROR 61.131



If the drive-processor detects an error, it switches off the motor.
After occurrence of a fault the green LED on the electronics (A1) flashes quickly.

FU/CCI-ERROR 60

Error when checking the enable signal to frequency converter (drive-processor).

No further user operation possible except opening the lid.

- Reset error code:
Perform a MAINS RESET.
- Electronics (A1) is defective.

FU/CCI-ERROR 61.1 Undervolt

Frequency converter error. Undervoltage in the intermediate circuit.

The rotor slows down without braking until it stops.

No further user operation possible except opening the lid.

- Reset error code:
Perform a MAINS RESET.
- Mains voltage is too low. Admissible mains voltage see pg. 98, chapter 12.4.
- Electronics (A1) is defective.

FU/CCI-ERROR 61.2 Overvolt

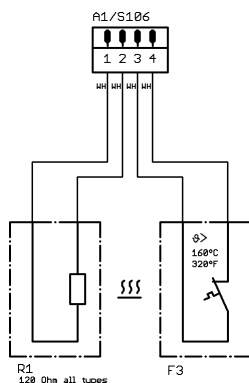

Frequency converter error. Overvoltage.

The voltage in intermediate circuit is > 426 V DC.

This error normally only occurs when the drive is being braked.

The rotor slows down without braking until it stops.

No further user operation possible except opening the lid.

- Reset error code:
Perform a MAINS RESET.
- Check the electrical wiring and the plug S106 of the brake resistor (R1).
- Brake resistor (R1) is defective.
- Electronics (A1) is defective.

FU/CCI-ERROR 61.4 OverT FU

Overtemperature in the frequency converter.
Temperature $\geq 78^{\circ}\text{C}$ / 172°F .

The rotor slows down without braking until it stops.
No further user operation possible except opening the lid.

- Reset error code:
Perform a MAINS RESET.
- The thermal conduction from the frequency converter to the supporting sheet of the electronics (A1) is not sufficient.
- Full load operation at an ambient temperature $> 35^{\circ}\text{C}$ / 95°F .
- Electronics (A1) is defective.

FU/CCI-ERROR 61.5 OverT Mot

Overtemperature in the motor. Temperature $> 150^{\circ}\text{C}$ / 302°F .

The rotor slows down without braking until it stops.
No further user operation possible except opening the lid.

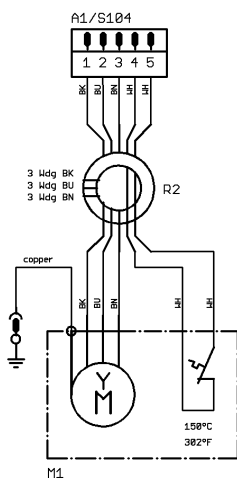

E2753 (250V) = 2,1 ohms between 2 motorwires
at cold motor ca. $+15...30^{\circ}\text{C}$
at cold motor ca. $+59^{\circ}\text{F}...86^{\circ}\text{F}$

- Reset error code:
Perform a MAINS RESET.
- Overtemperature switch opens because of overtemperature in the motor.
Remove plug S104 and measure at the plug between pin 4 - pin 5:
Switch closed: $\approx 0 \Omega$
Switch opened: $\infty \Omega$
- Electronics (A1) is defective.
- Motor is defective.

FU/CCI-ERROR 61.9 OverI Peak

Overcurrent in the frequency converter (peak current).

The rotor slows down without braking until it stops.
No further user operation possible except opening the lid.

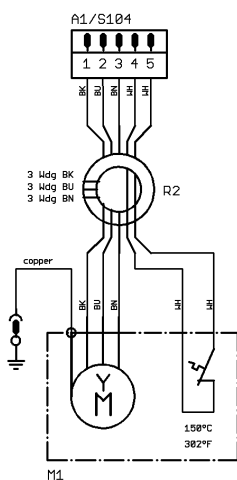

E2753 (250V) = 2,1 ohms between 2 motorwires
at cold motor ca. $+15...30^{\circ}\text{C}$
at cold motor ca. $+59^{\circ}\text{F}...86^{\circ}\text{F}$

- Reset error code:
Perform a MAINS RESET.
- Short circuit in the motor.
Remove plug S104 and check at the plug pin 1, pin 2, pin 3 the resistance of the motor coils.
- Electronics (A1) is defective.

FU/CCI-ERROR 61.13 Short cir

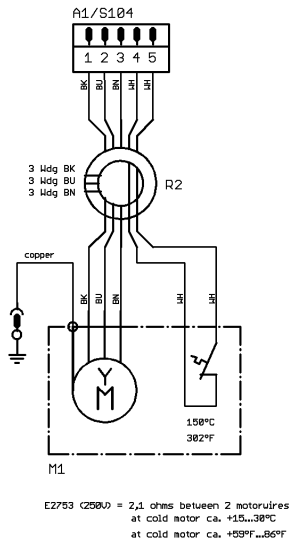

Short circuit switch-off of the frequency converter.

The rotor slows down without braking until it stops.
No further user operation possible except opening the lid.

- Reset error code:
Perform a MAINS RESET.
- Short circuit in the motor.
Remove plug S104 and check at the plug pin 1, pin 2, pin 3 the resistance of the motor coils.
- Electronics (A1) is defective.

FU/CCI-ERROR 61.16 FU Enable

No enabling for frequency converter.

The rotor slows down without braking until it stops.
No further user operation possible.

- Reset error code:
Perform a MAINS RESET.
- Switches of the lid lock defective.
Check the function of both switches, see chapter "7.17, item 21".
Pull out plug S703 and check the function of the switches at the plug of the cable between pin 1 - pin 2 (left hook) and pin 3 - pin 4 (right hook).
- Electronics (A1) is defective.

FU/CCI-ERROR 61.17

Communication error with control-processor.

The rotor slows down without braking until it stops.
No further user operation possible.

- Reset error code:
Perform a MAINS RESET.
- Electronics (A1) is defective.

FU/CCI-ERROR 61.18

Frequency converter receives wrong direction of rotation command.
 The rotor slows down without braking until it stops.
 No further user operation possible.

- Reset error code:
Perform a MAINS RESET.
- Electronics (A1) is defective.

FU/CCI-ERROR 61.19 Overspeed

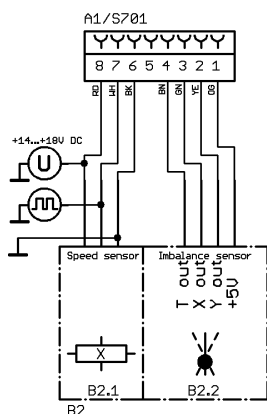

The frequency converter recognises excess speed. It evaluates the signals from the speed sensor (B2.1) at the bottom of the motor.
 The error occurs, if the speed measured by the speed sensor (B2.1) is longer as 0.5 seconds 250 RPM higher than the maximum speed of the rotor (Nmax).

The rotor slows down without braking until it stops.
 No further user operation possible.

- Reset error code:
Perform a MAINS RESET.
- Speed sensor (B2.1) at the bottom of the motor defective or loose contact on plug.
Measure supply voltage on plug S701 / Electronics (A1) pin 6 – pin 8 (+14-18 VDC).
Measure speedometer pulses on plug S701 / Electronics (A1) pin 6 - pin 7 (signal).
- Electronics (A1) is defective.

FU/CCI-ERROR 61.20

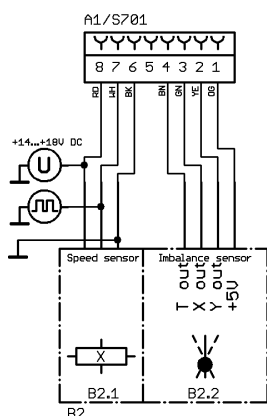

Faulty speed measurement of the frequency converter.

The rotor slows down without braking until it stops.
 No further user operation possible.

- Reset error code:
Perform a MAINS RESET.
- Speed sensor (B2.1) at the bottom of the motor defective or loose contact on plug.
Measure supply voltage on plug S701 / Electronics (A1) pin 6 – pin 8 (+14-18 VDC).
Measure speedometer pulses on plug S701 / Electronics (A1) pin 6 - pin 7 (signal).
- Electronics (A1) is defective.

FU/CCI-ERROR 61.128

Internal frequency converter error.

The rotor slows down without braking until it stops.

No further user operation possible.

- Reset error code:
Perform a MAINS RESET.
- Electronics (A1) is defective.

FU/CCI-ERROR 61.129

System error of the frequency converter.

The rotor slows down without braking until it stops.

No further user operation possible.

- Reset error code:
Perform a MAINS RESET.
- Electronics (A1) is defective.

FU/CCI-ERROR 61.130

Program memory of the frequency converter defective.

The rotor slows down without braking until it stops.

No further user operation possible.

- Reset error code:
Perform a MAINS RESET.
- Electronics (A1) is defective.

FU/CCI-ERROR 61.131

Reset by Watchdog of the frequency converter.

The rotor slows down without braking until it stops.

No further user operation possible.

- Reset error code:
Perform a MAINS RESET.
- Electronics (A1) is defective.

SENSOR - ERROR 90 (nur bei Zentrifuge mit Kühlung)

No mains synchronisation.

The rotor slows down braked until it stops.

No further user operation possible.

- Reset error code:
Perform a MAINS RESET.
- Electronics (A1) is defective.

SENSOR - ERROR 91 - 92

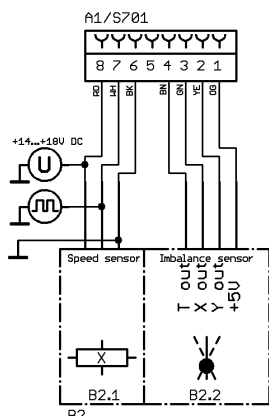

Imbalance sensor error.

SENSOR - ERROR 91 = x-axis, SENSOR - ERROR 92 = y-axis

The rotor slows down braked until it stops.

No further user operation possible.

- Reset error code:
Perform a MAINS RESET.
- Check the plug S701 and the wires.
- Imbalance sensor (B2.2) is defective.
Measure supply voltage on plug S701 / Electronics (A1) pin 6 – pin 1 (+5 VDC).
Measure on Electronics (A1) / plug S701, pin 6 – pin 2 and pin 6 – pin 3 (square wave signal 5 V /100 Hz).
- Check the function of the imbalance sensor, see pg. 63, chapter 7.17, item 5.
- Electronics (A1) is defective.

SENSOR - ERROR 93

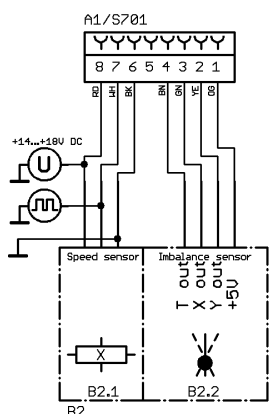

The temperature of the imbalance sensor is out of the valid range.

The rotor slows down braked until it stops.

No further user operation possible.

- Reset error code:
Perform a MAINS RESET.
- Imbalance sensor (B2.2) is defective.
Measure supply voltage on plug S701 / Electronics (A1) pin 6 – pin 1 (+5 VDC).
Measure voltage "Tout" on plug S701 / Electronics (A1) pin 6 – pin 4.
Valid voltage range: 0.5 V up to 2.00 V.
Voltage at 25°C / 77°F = 1.25 V (± 40 mV).
A temperature change of 1°K causes a voltage change of 5 mV.
- Electronics (A1) is defective.

TACHO – ERROR 96 wait 3:00

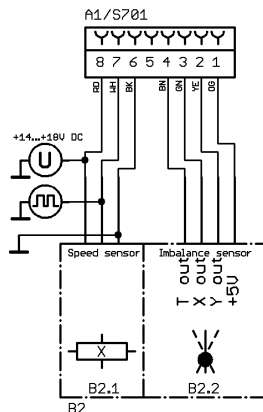

During centrifugation the speedometer pulses of the speed sensor (B2.1) at the bottom of the motor are interrupted.

The rotor slows down braked until it stops.

No further user operation possible.

After the rotor is at standstill and the 3 minutes have elapsed the lid lock will be released and the lid can be opened.

- Reset error code:
 - Open the lid.
 - Switch off the mains switch (switch position "0").
 - Wait at least 10 seconds.
 - Turn the rotor vigorously by hand.
 - Switch on the mains switch again (switch position "I"). The rotor must turn during switch-on.
- Speed sensor (B2.1) at the bottom of the motor defective or loose contact on plug. Check the function of the speed sensor (B2.1), see pg. 63, chapter 7.17, item 6. Measure supply voltage on plug S701 / Electronics (A1) pin 6 – pin 8 (+14-18 VDC). Measure speedometer pulses on plug S701 / Electronics (A1) pin 6 - pin 7 (signal).
- Electronics (A1) is defective.

°C / *-ERROR 97

The temperature measured by the temperature sensor on the electronics (A1) is out of the valid range.

The rotor slows down braked until it stops.

No further user operation possible.

- Reset error code: Perform a MAINS RESET.
- Electronics (A1) is defective.

°C / *-ERROR 98

The temperature sensor on the electronics (A1) measures a temperature of $\geq 60^{\circ}\text{C}$ / $\geq 140^{\circ}\text{F}$.

The rotor slows down braked until it stops.

No further user operation possible.

- Reset error code: Perform a MAINS RESET.
- Electronics (A1) is defective.

PROGRAMM-ERROR 100

Check sum error with programs (single programs).

The rotor slows down braked until it stops.

No further user operation possible.

- Reset error code:
Perform a MAINS RESET.
- Delete all programs (single programs), see pg. 69, chapter 7.18.
- ☞ The centrifugation data in all programs will be overwrite with default values.
- Electronics (A1) is defective.

MULTI PROG ERROR 101

Check sum error with program linking (multi programs).

The rotor slows down braked until it stops.

No further user operation possible.

- Reset error code:
Perform a MAINS RESET.
- Delete all program linking (multi programs), see pg. 69, chapter 7.18.
- ☞ All program linking will be canceled.
- Electronics (A1) is defective.

NO ROTOR OR ROTORCODE ERROR

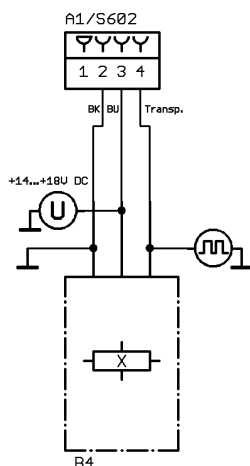

After start-up no speedometer pulses will be received from the speed sensor (B4) on top of the motor.

The rotor slows down braked until it stops.

No further user operation possible.

- Reset error code:
Open the lid.
- No rotor installed.
- Speed sensor (B4) on top of the motor defective or loose contact on plug.
- Measure supply voltage on plug S602 / Electronics (A1)
pin 2 – pin 3 (+14-18 VDC).
- Measure speedometer pulses on plug S602 / Electronics (A1)
pin 2 - pin 4 (signal).
- Electronics (A1) is defective.

N > ROTOR MAX

Speed in the selected program greater than the maximum speed of the rotor.

No start possible.

- Check and reduce the set speed.

FC INIT ERROR

Initialisation of the frequency converter is faulty.

No further user operation possible except opening the lid.

- Reset error code:
Perform a MAINS RESET.
- Electronics (A1) is defective.

FATAL EEPROM ERROR 1 – 5

EEPROM error.

No further user operation possible except opening the lid.

- Reset error code:
Perform a MAINS RESET.
- Initialise the EEPROM, see pg. 71, chapter 7.20.
- Electronics (A1) is defective.

7 Settings and interrogations

All settings and interrogations are performed via the keyboard.

The corresponding menus are selected by pressing keys or combinations of keys.

7.1 Summary of the possible settings and interrogations

Acoustic signal, see pg. 39, chapter 7.4.

Address of the centrifuge, see pg. 42, chapter 7.7.

Automatic repetition of the centrifugation run, see pg. 72, chapter 7.21.

Centrifugation data displayed after switch-on, see pg. 41, chapter 7.5.

Centrifuge model, see pg. 50, chapter 7.12.

Display of the centrifuge model, see pg. 51, chapter 7.13.

Functions Ramp Unit, RCF-Integral, B-Ramp and Multi programs, see pg. 42, chapter 7.6.

EEPROM, see pg. 70, chapter 7.19 and pg. 71, chapter 7.20.

Function test of the individual components, see pg. 63, chapter 7.17.

Imbalance switch-off, see pg. 60, chapter 7.15.3.

Imbalance values, see pg. 58, chapter 7.15.1 and pg. 59, chapter 7.15.2.

Logged faults, see pg. 43, chapter 7.8.

Logged events, see pg. 46, chapter 7.9.

Number of the centrifugation runs, see pg. 38, chapter 7.3.

Operating hours, see pg. 38, chapter 7.3.

Programs and program linking delete, see pg. 69, chapter 7.18.

System information, see pg. 37, chapter 7.2.

Serial interface, see pg. 62, chapter 7.16.

Speed sensor check, see pg. 49, chapter 7.11.

Speed values, see pg. 48, chapter 7.10.

Temperature sensors, see pg. 55, chapter 7.14.3 and pg. 56, chapter 7.14.4.

Temperature unit, see pg. 52, chapter 7.14.1.

Temperature values, see pg. 53, chapter 7.14.2.

7.2 Inquiry the system information



The Inquiry of the system information is only possible if the rotor is at standstill.

In the menu "info" it is possible to jump back to the parameter indicated before by pressing the T°C key.

It is at any time possible to terminate the procedure by pressing the STOP/OPEN key.

Action	Display / Comment
1. Switch on the mains switch.	→ e.g. ROTINA 380 R Centrifuge model
	→ e.g. V 01.01 Program version
	→ e.g. Rotor 4 Nmax=4500 R=184 Rotor information
	→ e.g. 6 20 9/9 4000 5:20 Display of the centrifugation data.
2. Keep the PROG key pressed for 8 seconds.	→ e.g. RCL 4
Display after 8 seconds.	→ *** Machine Menu ***
3. Press the PROG key.	→ -> Info
4. Press the START key.	→ e.g. Rotor 4* : Nmax = 4500 R=184 Rotor information of the rotor last recognized by the rotor identification (Rotor = rotor code, Nmax = maximum speed of the rotor, R = preset centrifugation radius). The last recognized rotor is marked by a star (*).
• Turn the control knob \odot .	→ e.g. Rotor 5 : Nmax = 14000 R=86 With the control knob \odot now the information of the rotors approved in the centrifuge can be displayed.
5. Press the PROG key.	→ e.g. SW-Version = 01.02 Program version of the centrifuge.
6. Press the PROG key.	→ e.g. FC-SW-Version = 4 Program version of the frequency converter.

Action	Display / Comment
7. To exit the menu press the STOP / OPEN key three times.	→ -> Info → *** Machine Menu *** → e.g. 6 20 9/ 9 4000 5:20 Display of the centrifugation data.

7.3 Inquire and change the operating hours and inquire the number of the centrifugation runs

The operating hours are divided up into internal and external operating hours.

Internal operating hours: Total time the device was switched on.

External operating hours: Total time of previous centrifugation runs.



Only the external operating hours can be set.

The inquiry and the change of the external operating hours and the inquiry of the number of centrifugation runs is only possible if the rotor is at standstill.

In the menu "Operating Time" it is possible to jump back to the parameter indicated before by pressing the **T/°C** key.

It is at any time possible to terminate the procedure by pressing the **STOP / OPEN** key. In this case the adjustments are not saved.

Action	Display / Comment
1. Switch on the mains switch.	→ e.g. ROTINA 380 R Centrifuge model → e.g. V 01.01 Program version → e.g. Rotor 4 Nmax=4500 R=184 Rotor information → e.g. 6 20 9/ 9 4000 5:20 Display of the centrifugation data.
2. Keep the PROG key pressed for 8 seconds. Display after 8 seconds.	→ e.g. RCL 4 → *** Machine Menu ***
3. Press the PROG key so often until the following will be displayed:	→ -> Operating time

Action	Display / Comment
4. Press the START key.	→ e.g. OP Time ext = 89h27m External operating hours.  If the external operating hours should not be changed, press the PROG key to inquire the internal operating hours.
5. Press the RCF key.	→ e.g. OP Time ext = < 89h27m > The external operating hours are now adjustable.
• Turn the control knob 0 .	→ e.g. OP Time ext = < 60h27m > Set the external operating hours.
6. Press the START key.	→ Store OP Time ext ... The setting will be stored. → e.g. OP Time ext = 60h27m Changed external operating hours.
7. Press the PROG key.	→ e.g. OP Time int = 145h10m Internal operating hours (not adjustable).
8. Press the PROG key.	→ e.g. Number of Starts = 1495 Number of the centrifugation runs.
9. To exit the menu press the STOP / OPEN key three times.	→ -> Operating time → *** Machine Menu *** → e.g. 6 20 9/ 9 4000 5:20 Display of the centrifugation data.

7.4 Set the acoustic signal

The acoustic signal sounds:

- Upon the appearance of a disturbance in 2 second intervals.
- After completion of a centrifugation run and rotor standstill in 30 second intervals.

The acoustic signal is stopped by opening the lid or pressing any key.



The signal after completion of the centrifugation run can be activated or deactivated, if the rotor is at standstill.

In the menu "Settings" it is possible to jump back to the parameter indicated before by pressing the **T/°C** key.

It is at any time possible to terminate the procedure by pressing the **STOP / OPEN** key. In this case the adjustments are not saved.

Action	Display / Comment
1. Switch on the mains switch.	<p>→ e.g. ROTINA 380 R Centrifuge model</p> <p>→ e.g. V 01.01 Program version</p> <p>→ e.g. Rotor 4 Nmax=4500 R=184 Rotor information</p> <p>→ e.g. 6 20 9/∧ 9 4000 5:20 Display of the centrifugation data.</p>
2. Keep the PROG key pressed for 8 seconds.	→ e.g. RCL 4
Display after 8 seconds.	→ *** Machine Menu ***
3. Press the PROG key so often until the following will be displayed:	→ -> Settings
4. Press the START key.	→ Sound / Bell = off/on off = acoustic signal deactivated. on = acoustic signal activated.
• Turn the control knob 0 .	→ Sound / Bell = off/on Set "off" or "on".
5. Press the START key.	→ Store settings ... The setting will be stored.
	→ -> Settings
6. To exit the menu press the STOP / OPEN key twice.	<p>→ *** Machine Menu ***</p> <p>→ e.g. 6 20 9/∧ 9 4000 5:20 Display of the centrifugation data.</p>

7.5 Set the centrifugation data displayed after switch-on

After switch-on the centrifugation data from program 1, or from the last program that was used, is displayed.



The setting of the centrifugation data displayed after switch-on is only possible if the rotor is at standstill.

In the menu "Settings" it is possible to jump back to the parameter indicated before by pressing the **T/°C** key.

It is at any time possible to terminate the procedure by pressing the **STOP / OPEN** key. In this case the adjustments are not saved.

Action	Display / Comment
1. Switch on the mains switch.	<p>→ e.g. ROTINA 380 R Centrifuge model</p> <p>→ e.g. V 01.01 Program version</p> <p>→ e.g. Rotor 4 Nmax=4500 R=184 Rotor information</p> <p>→ e.g. 6 20 9/9 4000 5:20 Display of the centrifugation data.</p>
2. Keep the PROG key pressed for 8 seconds.	→ e.g. RCL 4
Display after 8 seconds.	→ *** Machine Menu ***
3. Press the PROG key so often until the following will be displayed:	→ -> Settings
4. Press the START key.	→ Sound / Bell = off/on Acoustic signal.
5. Press the PROG key so often until the following will be displayed:	→ Start program = Last/First Displayed program after switch-on.
<ul style="list-style-type: none"> • Turn the control knob 0. 	<p>→ Start program = Last/First Set "Last" or "First". Last = last used program, First = program 1.</p>

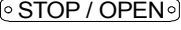
Action	Display / Comment
6. Press the  key.	→ Store settings ... The setting will be stored. → -> Settings
7. To exit the menu press the  key twice.	→ *** Machine Menu *** → e.g. 6 20 9/9 4000 5:20 Display of the centrifugation data.

7.6 Set the functions Ramp Unit, RCF-Integral, B-Ramp and Multi programs

 These functions are not activated by default.

7.7 Set the address of the centrifuge

 Ex works the address is set to] = 29. address. This address may not be changed.

7.8 Logging the occurred faults

The data of the 32 last occurred faults are stored and can be queried.



The inquiry of the occurred faults is only possible if the rotor is at standstill. It is at any time possible to terminate the procedure by pressing the **STOP/OPEN** key.

Action	Display / Comment
1. Switch on the mains switch.	<ul style="list-style-type: none"> → e.g. ROTINA 380 R Centrifuge model → e.g. V 01.01 Program version → e.g. Rotor 4 Nmax=4500 R=184 Rotor information → e.g. 6 20 9/∧ 9 4000 5:20 Display of the centrifugation data.
2. Keep the PROG key pressed for 16 seconds.	→ e.g. RCL 4
Display after 8 seconds.	→ *** Machine Menu ***
Display after 16 seconds.	→ *** Service Menu ***
3. Press the PROG key.	→ -> Error History
4. Press the START key.	<ul style="list-style-type: none"> → e.g. #00 Errorcode = 06 #00 = last occurred fault. With the PROG key the last 32 faults (#00 bis #31) can be queried.
	<ul style="list-style-type: none">  If TACHO-ERROR 1.01 is indicated, then the last TACHO-ERROR 1 was not deleted. The SER I/O-ERROR 34 can also be displayed with index 1 to 3.

Action	Display / Comment
	Values of the parameters when the fault occurred:
<ul style="list-style-type: none"> • Turn the control knob  to the right. 	→ e.g. #00 Rotorcode = 4 Rotorcode
	→ e.g. #00 Mainstate = 0
	→ e.g. #00 State 1 = 8031
	→ e.g. #00 State 2 = 2383
	→ e.g. #00 State 3 = 0600 State of the machine.
	→ e.g. #00 Speed nom = 4500 Speed
	→ e.g. #00 Acc/Dec = 9/ 9 Run-up and run-down parameters.
	→ e.g. #00 Temp nom = -20 °C preselected temperature (set temperature).
	→ e.g. #00 Speed Rotor = 0 Speed value of the speed sensor (B4) on top of the motor.
	→ e.g. #00 Speed Motor = 0 Speed value of the speed sensor (B2.1) at the bottom of the motor.
	→ e.g. #00 Run time = 9:00 run time.
	→ e.g. #00 Temp act = 23 °C With ROTINA 380 R the parameters "Temp act" and "Temp T1" are identical.
	→ e.g. #00 Temp T1 = 23 °C Temperature value of the temperature sensor (B1) at the bottom of the centrifuge chamber.
	→ e.g. #00 Temp T2 = --- Temperature value of the temperature sensor (B2) at the top of the centrifuge chamber (does not exist in the ROTINA 380 R, therefore deactivated "---").
	→ e.g. #00 Temp T3 = 23 °C Temperature value of the temperature sensor (B3) on the condenser.
	→ e.g. #00 Temp Mot = 22 °C Temperature of the motor, measured from sensor (B2.2)
	→ e.g. #00 Temp Amb = 20 °C Temperature value of the temperature sensor on the electronics (A1).



Action

Display / Comment

Values of the parameters when the fault occurred:

- Turn the control knob  to the right.
 - e.g. **#00 FC Mode 000 = 0100**
 - e.g. **#00 FC Stat 051 = 8040**
State of the frequency converter.
 - e.g. **#00 FC Volt 015 = 329 V**
Value of the intermediate circuit voltage.
 - e.g. **#00 FC Temp 017 = 21 °C**
Temperature in the frequency converter.
 - e.g. **#00 Imbal act = 1 0**
imbalance values when the fault occurred.
 - e.g. **#00 Imbal max = 1 0**
maximum imbalance values during the centrifugation run.
 - e.g. **#00 OP Time int = 455h29m**
Internal operating hours.
 - e.g. **#00 OP Time ext = 390h18m**
External operating hours.

- Turn the control knob  to the left until the following will be displayed again:

- 5. Press the **PROG** key.
 - e.g. **#01 Errorcode = 61.01**
The next fault (#01) is displayed.
By turning the control knob  to the right the parameters described above can be queried.
With the **PROG** key the last 32 faults (#00 bis #31) can be queried.
 -  By pressing the **T/°C** key it is possible to jump back to the fault indicated before.

- 6. To exit the menu press the **STOP/OPEN** key three times.
 - **-> Error History**
 - ***** Service Menu *****
 - e.g. **6 20 9/ 9 4000 5:20**
Display of the centrifugation data.

7.9 Logging of certain procedures (events)

Each of the last 16 executions of the following procedures (events) are stored and can be queried:

- Rotor change,
- Setting the operating hours,
- Setting the imbalance switch-off,
- Compensation of the temperature sensors



The inquiry of the procedures (events) is only possible if the rotor is at standstill.

In the menu "Events" it is possible to jump back to the event indicated before by pressing the **T/°C** key.

It is at any time possible to terminate the procedure by pressing the **STOP / OPEN** key.

Action	Display / Comment
1. Switch on the mains switch.	<p>→ e.g. ROTINA 380 R Centrifuge model</p> <p>→ e.g. V 01.01 Program version</p> <p>→ e.g. Rotor 4 Nmax=4500 R=184 Rotor information</p> <p>→ e.g. 6 20 9/∧ 9 4000 5:20 Display of the centrifugation data.</p>
2. Keep the PROG key pressed for 16 seconds.	→ e.g. RCL 4
Display after 8 seconds.	→ *** Machine Menu ***
Display after 16 seconds.	→ *** Service Menu ***
3. Press the PROG key so often until the following will be displayed:	→ -> Events

Action	Display / Comment
4. Press the START key.	→ e.g. #0 Rotor Chg = 345h19m #0 = last rotor change. The displayed internal operating hours correspond to the time of the rotor change.
• Turn the control knob ○ to the right.	→ e.g. #1 Rotor Chg = 200h45m By turning the control knob ○ to the right the last 16 rotor changes (#0 bis #15) can be queried.
5. Press the PROG key.	→ e.g. #0 OP Time Chg = 150h23m #0 = last setting of the external operating hours. The displayed internal operating hours correspond to the time of the setting of the external operating hours.
• Turn the control knob ○ to the right.	→ e.g. #1 OP Time Chg = 100h05m By turning the control knob ○ to the right the last 16 settings of the external operating hours (#0 bis #15) can be queried.
6. Press the PROG key.	→ e.g. #0 Imbal Chg = 286h15m #0 = last setting of the imbalance switch-off. The displayed internal operating hours correspond to the time of the setting the imbalance switch-off.
• Turn the control knob ○ to the right.	→ e.g. #1 Imbal Chg = 120h00m By turning the control knob ○ to the right the last 16 settings of the imbalance switch-off (#0 bis #15) can be queried.
7. Press the PROG key.	→ e.g. #0 Offset Chg = 350h12m #0 = last compensation of the temperature sensors. The displayed internal operating hours correspond to the time of the compensation of the temperature sensors.
• Turn the control knob ○ to the right.	→ e.g. #1 Offset Chg = 50h25m By turning the control knob ○ to the right the last 16 compensations of the temperature sensors (#0 bis #15) can be queried.
8. To exit the menu press the STOP / OPEN key three times.	→ -> Events → *** Service Menu *** → e.g. 6 20 9/ 9 4000 5:20 Display of the centrifugation data.

7.10 Speed values during the centrifugation run



The inquiry of the speed values is only possible during the centrifugation run. It is possible to jump back to the previous display by pressing the **PROG** key. It is at any time possible to terminate the procedure by pressing the **STOP / OPEN** key.

Aktion	Anzeige / Kommentar
1. Switch on the mains switch.	→ e.g. ROTINA 380 R Centrifuge model → e.g. V 01.01 Program version → e.g. Rotor 4 Nmax=4500 R=184 Rotor information → e.g. 6 20 9/∧ 9 4000 5:20 Display of the centrifugation data.
2. Start a centrifugation run.	
3. Keep the T/°C key pressed for 8 seconds.	→ e.g. T/°C = 10
Display after 8 seconds.	→ e.g. Tn= 10 Ta= 26 Td= 27 *
4. Press the T/°C key so often until the following will be displayed:	→ e.g. RPM Rot= 4499 Field (Nstell¹)= 4526 Rot = Speed value of the speed sensor (B4) on top of the motor. Field (Nstell ¹) = Field speed. <small>1) with Software < V 01.04</small>  Slippage = (Field) - (Rot).
5. Press the T/°C key.	→ e.g. RPM Mot= 4498 Nom (Nsoll¹)= 4500 Mot = Speed value of the speed sensor (B2.1) at the bottom of the motor. Nom (Nsoll ¹) = Nominal speed value. <small>1) with Software < V 01.04</small>
6. To exit the inquiry press the STOP / OPEN key.	→ e.g. 6 20 9/∧ 9 4000 5:20 Display of the centrifugation data.
7. Press the STOP / OPEN key.	The centrifugation run is terminated.

7.11 Check both speed sensors



The check of both speed sensors is only possible if the rotor is at standstill. It is possible to jump back to the previous display by pressing the **PROG** key. It is at any time possible to terminate the procedure by pressing the **STOP / OPEN** key.

The both speed sensors can also be checked in the menu "Test".

Aktion	Anzeige / Kommentar
1. Switch on the mains switch.	<p>→ e.g. ROTINA 380 R Centrifuge model</p> <p>→ e.g. V 01.01 Program version</p> <p>→ e.g. Rotor 4 Nmax=4500 R=184 Rotor information</p> <p>→ e.g. 6 20 9/∧ 9 4000 5:20 Display of the centrifugation data.</p>
2. Open the lid.	
3. Keep the T/°C key pressed for 8 seconds.	→ e.g. T/°C = 10
Display after 8 seconds.	→ e.g. Tn= 10 Ta= 26 Td= 27
4. Press the T/°C key so often until the following will be displayed:	<p>→ e.g. RPM Rot= 0 Mot= 0</p> <p>Rot = Speed value of the speed sensor (B4) on top of the motor.</p> <p>Mot = Speed value of the speed sensor (B2.1) at the bottom of the motor.</p>
	<p> Function test of the speed sensors: Turn the rotor by hand. Speed values must be displayed.</p>
5. To exit the inquiry press the STOP / OPEN key.	<p>→ e.g. 6 20 9/∧ 9 4000 5:20 Display of the centrifugation data.</p>

7.12 Set the centrifuge model

The centrifuge model, which is displayed after switch-on can be set.

Model	Description
ROTINA 380	Centrifuge without cooling
ROTINA 380 R	Centrifuge with cooling
ROTINA 380 RH	Centrifuge with option heating/cooling



The setting of the centrifuge model is only possible if the rotor is at standstill. It is at any time possible to terminate the procedure by pressing the **STOP/OPEN** key. In this case the adjustments are not saved.

Action	Display / Comment
1. Keep the START key and the STOP/OPEN key pressed and switch on the mains switch at the same time.	→ *** Select Menu ***
2. Press the PROG key.	→ -> Version
3. Press the START key.	→ e.g. ROTINA 380 Centrifuge model
• Turn the control knob ⌚.	→ e.g. ROTINA 380 R Set the Centrifuge model.
4. Press the START key.	→ Store Version ... The setting will be stored. → e.g. ROTINA 380 R
5. To exit the menu press the STOP/OPEN key three times.	→ -> Version → *** Select Menu *** → e.g. 6 20 9/9 4000 5:20 Display of the centrifugation data.

7.13 Blank the centrifuge model in the display

The display of the centrifuge model after switching on the unit can be blanked.
With OEM-units the display of the centrifuge model must be blanked.



To blank the display of the centrifuge model is only possible if the rotor is at standstill.

It is at any time possible to terminate the procedure by pressing the **STOP / OPEN** key. In this case the adjustments are not saved.

Action	Display / Comment
1. Keep the START key and the STOP / OPEN key pressed and switch on the mains switch at the same time.	→ *** Select Menu ***
2. Press the PROG key so often until the following will be displayed:	→ -> Setup
3. Press the START key.	→ OEM Version = off/on off = Centrifuge model is displayed on = Centrifuge model is not displayed (only with OEM-units).
• Turn the control knob \odot .	→ OEM Version = off/on Set "off" or "on"..
4. Press the START key.	→ Store Setup ... The setting will be stored. → -> Setup
5. To exit the menu press the STOP / OPEN key twice.	→ *** Select Menu *** → e.g. 6 20 9/9 4000 5:20 Display of the centrifugation data.

7.14 Cooling parameters

7.14.1 Set the temperature unit

The temperature can be entered in degrees Celsius (°C) or in degrees Fahrenheit (°F).



The setting of the temperature unit is only possible if the rotor is at standstill. In the menu "Settings" it is possible to jump back to the parameter indicated before by pressing the $\overline{T/^\circ\text{C}}$ key.

It is at any time possible to terminate the procedure by pressing the $\overline{\text{STOP/OPEN}}$ key. In this case the adjustments are not saved.

Action	Display / Comment
1. Switch on the mains switch.	→ e.g. ROTINA 380 R Centrifuge model
	→ e.g. V 01.01 Program version
	→ e.g. Rotor 4 Nmax=4500 R=184 Rotor information
	→ e.g. 6 20 9/∧ 9 4000 5:20 Display of the centrifugation data.
2. Keep the $\overline{\text{PROG}}$ key pressed for 8 seconds.	→ e.g. RCL 4
Display after 8 seconds.	→ *** Machine Menu ***
3. Press the $\overline{\text{PROG}}$ key so often until the following will be displayed:	→ -> Settings
4. Press the $\overline{\text{START}}$ key.	→ Sound / Bell = off/on Acoustic signal.
5. Press the $\overline{\text{PROG}}$ key so often until the following will be displayed:	→ Temp Unit = Celsius/Fahrenheit The set temperature unit.
• Turn the control knob $\overline{\text{O}}$.	→ Temp Unit = Celsius/Fahrenheit Set Celsius (°C) or Fahrenheit (°F).

Action	Display / Comment
6. Press the START key.	→ Store settings ... The setting will be stored. → -> Settings
7. To exit the menu press the STOP / OPEN key twice.	→ *** Machine Menu *** → e.g. 6 68F 9/9 4000 5:20 Display of the centrifugation data.

7.14.2 Inquire the temperature values



The inquiry of the temperature values is possible if the rotor is at standstill or during the centrifugation run.

It is possible to jump back to the previous display by pressing the **PROG** key.

It is at any time possible to terminate the procedure by pressing the **STOP / OPEN** key.

Action	Display / Comment
1. Switch on the mains switch.	→ e.g. ROTINA 380 R Centrifuge model → e.g. V 01.01 Program version → e.g. Rotor 4 Nmax=4500 R=184 Rotor information → e.g. 6 20 9/9 4000 5:20 Display of the centrifugation data.
2. Start a centrifugation run.	If an inquiry of the temperature values is required during the centrifugation run.
3. Keep the T/°C key pressed for 8 seconds.	→ e.g. T/°C = 10
Display after 8 seconds.	→ e.g. Tn= 10 Ta= 28 Td= 27 * Tn = Nominal temperature value. Ta = Current temperature in the centrifuge chamber (= temperature value of temperature sensor B1). Td = Temperature value in the display. * = Cooling is switched on.

Action	Display / Comment
4. Press the $\boxed{T/^{\circ}C}$ key.	→ e.g. T1= 28 T2= --- T3= 22 * T1 = Temperature value of the temperature sensor (B1) at the bottom of the centrifuge chamber. T2 = Temperature value of the temperature sensor (B2) at the top of the centrifuge chamber. ("---" is displayed because the ROTINA 380 R has no temperature sensor (B2)). T3 = Temperature value of the temperature sensor (B3) at the condenser. * = Cooling is switched on.
5. Press the $\boxed{T/^{\circ}C}$ key.	→ e.g. Tamb= 29 Tmot= 34 Tamb = Temperature value of the temperature sensor on the electronics (A1). Tmot = Temperature value of the temperature sensor in the imbalance sensor (B2.2) (motor temperature).
6. Press the $\boxed{T/^{\circ}C}$ key.	→ e.g. T FC= 30 T Ir= --- T Ex= --- T FC = Temperature in the frequency converter. T Ir = Temperature value of an external sensor (does not exist in ROTINA 380 / 380 R). T Ex = Temperature value of an external sensor (does not exist in ROTINA 380 / 380 R).
7. To exit the inquiry press the STOP/OPEN key.	→ e.g. 6 20 9/9 4000 5:20 Display of the centrifugation data.
8. Press the STOP/OPEN key.	The centrifugation run is terminated.

7.14.3 Deactivate the temperature sensor (B2) at the top of the centrifuge chamber

The ROTINA 380 R / 380 RH has no temperature sensor (B2) at the top of the centrifuge chamber and therefore the temperature sensor (B2) must be absolutely deactivated in the program. The temperature sensor (B2) is ex factory deactivated.

Only with centrifuges that have at the top of the centrifuge chamber the temperature sensor (B2) this sensor must be activated in the program.



The deactivation of the temperature sensor (B2) is only possible if the rotor is at standstill.

It is at any time possible to terminate the procedure by pressing the **STOP / OPEN** key. In this case the adjustments are not saved.

Action	Display / Comment
1. Keep the START key and the STOP / OPEN key pressed and switch on the mains switch at the same time.	→ *** Select Menu ***
2. Press the PROG key so often until the following will be displayed:	→ -> Setup
3. Press the START key.	→ OEM Version = off/on
4. Press the PROG key	→ T2 Sensor = --- / ok. --- = Temperature sensor deactivated. ok. = Temperature sensor activated.
• Turn the control knob \odot .	→ T2 Sensor = --- Set "---" because the ROTINA 380 R has no temperature sensor B2 (= T2).
5. Press the START key.	→ Store Setup ... The setting will be stored. → -> Setup
6. To exit the menu press the STOP / OPEN key twice.	→ *** Select Menu *** → e.g. 6 20 9/9 4000 5:20 Display of the centrifugation data.

7.14.4 Compensate the temperature sensors

The offset compensation is carried out to correct the measurement deviations of the temperature sensors (B1, B3) and the Electronics (A1).

T1 = Temperature value of the temperature sensor (B1) at the bottom of the centrifuge chamber.

T2 = Temperature value of the temperature sensor (B2) at the top of the centrifuge chamber.

Temperature sensor (B2) does not exist in ROTINA 380 R 380 RH.

T3 = Temperature value of the temperature sensor (B3) on the condenser.

An offset compensation must be carried out::

- after replacing a temperature sensor
- after changing the software of the control processor
- after deleting the EEPROM
- after replacing the Electronics (A1)





In order to prevent measuring errors during the temperature measurement, a constant temperature should be at the temperature sensors during the offset compensation.

The offset compensation is only possible if the rotor is at standstill and the lid is opened.

It is at any time possible to terminate the procedure by pressing the **STOP/OPEN** key. In this case the adjustments are not saved.

Action	Display / Comment
--------	-------------------

- | | |
|--------------------------------------------------------------------------------------------------------------------|------------------------------|
| 1. Keep the START key and the STOP/OPEN key pressed and switch on the mains switch at the same time. | → *** Select Menu *** |
| 2. Press the PROG key so often until the following will be displayed: | → -> Offset |

Action	Display / Comment
3. Press the START key.	<p>→ e.g. T1/°C +26.0 +25.5 -0.5</p> <p> If OPEN LID !! will be displayed, press the STOP / OPEN key.</p> <p>T1/°C = Temperature value of the temperature sensor at the bottom of the centrifuge chamber. °C = in degree Celsius, °F = in degree Fahrenheit.</p> <p> Setting the temperature unit see chapter "7.14.1".</p> <p>+26.0 = Temperature measured by the temperature sensor (B1). +25.5 = corrected temperature (actual temperature). -0.5 = Offset-value</p> <ul style="list-style-type: none"> • Turn the control knob 0. <p>Measure the temperature T1 with a temperature measuring device at the temperature sensor (B1) at the bottom of the centrifuge chamber and set the value. Settable in steps of 0.5° C.</p>
4. Press the PROG key.	<p>→ e.g. T3/°C +24.0 +25.5 +1.5</p> <p>T3/°C = Temperature value of the temperature sensor (B3) on the condenser. °C = in degree Celsius, °F = in degree Fahrenheit.</p> <p> Setting the temperature unit see chapter "Set the temperature unit".</p> <p>+24.0 = Temperature measured by the temperature sensor (B3). +25.5 = corrected temperature (actual temperature). +1.5 = Offset-value</p> <ul style="list-style-type: none"> • Turn the control knob 0. <p>Measure the temperature T3 with a temperature measuring device at the temperature sensor (B3) at the bottom of the centrifuge chamber and set the value. Settable in steps of 0.5° C.</p>
5. Press the START key.	<p>→ Store Offset ... The set temperatures T1 and T3 will be stored.</p> <p>e.g. T3/°C +24.0 +25.5 +1.5</p> <p>→</p>
6. To exit the menu press the STOP / OPEN key three times.	<p>→ -> Offset</p> <p>→ *** Select Menu ***</p> <p>→ e.g. 6 20 9/ 9 4000 5:20 Display of the centrifugation data.</p>

7.15 Imbalance values

7.15.1 Logging the maximum imbalance values

The maximum imbalance values of the last 100 centrifugation runs are stored and can be queried.



The inquiry of the stored maximum imbalance values is only possible if the rotor is at standstill.

It is at any time possible to terminate the procedure by pressing the **STOP / OPEN** key.

Action	Display / Comment
1. Switch on the mains switch.	→ e.g. ROTINA 380 R Centrifuge model
	→ e.g. V 01.01 Program version
	→ e.g. Rotor 4 Nmax=4500 R=184 Rotor information
	→ e.g. 6 20 9/ 9 4000 5:20 Display of the centrifugation data.
2. Keep the PROG key pressed for 16 seconds.	→ e.g. RCL 4
Display after 8 seconds.	→ *** Machine Menu ***
Display after 16 seconds.	→ *** Service Menu ***
3. Press the PROG key so often until the following will be displayed:	→ -> Imbal History
4. Press the START key.	→ e.g. #0 RC = 6 XmYm = 4 : 4 N = 2220 #0 = last centrifugation run. RC = rotorcode of the rotor. Xm = maximum X-value in per cent of the imbalance sensor. Ym = maximum Y-value in per cent of the imbalance sensor. N = speed at which the maximum imbalance had occurred.

Action	Display / Comment
<ul style="list-style-type: none"> Turn the control knob \odot to the right. 	<ul style="list-style-type: none"> → e.g. #1 RC = 6 XmYm = 5 : 5 N = 790 The maximum imbalance values of the next centrifugation run will be displayed. By turning the control knob \odot to the right the maximum imbalance values of the last 100 centrifugation runs (#0 bis #99) can be queried.
5. To exit the menu press the \odot STOP/OPEN \odot key three times.	<ul style="list-style-type: none"> → -> Imbal History → *** Service Menu *** → e.g. 6 20 9/\ 9 4000 5:20 Display of the centrifugation data.

7.15.2 Inquiry the current and the maximum imbalance values





The inquiry of the current and the maximum imbalance values is possible if the rotor is at standstill or during the centrifugation run.

It is possible to jump back to the previous display by pressing the \square PROG \square key.

It is at any time possible to terminate the procedure by pressing the \odot STOP/OPEN \odot key.

Action	Display / Comment
1. Switch on the mains switch.	<ul style="list-style-type: none"> → e.g. ROTINA 380 R Centrifuge model → e.g. V 01.01 Program version → e.g. Rotor 4 Nmax=4500 R=184 Rotor information → e.g. 6 20 9/\ 9 4000 5:20 Display of the centrifugation data.
2. Start a centrifugation run.	The inquiry of the current imbalance values makes only sense during a centrifugation run.
3. Keep the \square T/°C \square key pressed for 8 seconds.	→ e.g. T/°C = 10
Display after 8 seconds.	→ e.g. Tn= 10 Ta= 26 Td= 27 *

- | Action | Display / Comment |
|----------------------------------------------------------------------------------------------------------------------------------------------------|---------------------------------------------------------------------------------------------------------------------------------------------------------------------------------------------------------------------------------------------------------------------------------------------|
| 4. Press the  key so often until the following will be displayed: | → e.g. Imb Xa= 0 Ya= 1 Xm= 1 Ym= 3
Xa = actual X-value in per cent of the imbalance sensor.
Ya = actual Y-value in per cent of the imbalance sensor.
Xm = maximum X-value in per cent of the imbalance sensor.
Ym = maximum Y-value in per cent of the imbalance sensor. |
| 5. To exit the inquiry press the  key. | → e.g. 6 20 9/9 4000 5:20
Display of the centrifugation data. |
| 6. Press the  key. | The centrifugation run is terminated. |

7.15.3 Setting the imbalance switch-off



A change of the imbalance switch-off affects all rotors.

The imbalance switch-off is specified by the indication of the difference in weight of opposite rotor positions.

In the factory the imbalance switch-off will be adjusted with rotor 1754.

With swing-out rotors all rotor positions must be lined with **identical** hangers.

By a test run with empty rotor, and that for the rotor specified switch-off weight in one rotor place the imbalance switch-off is checked, see following table.



With the switch-off weight specified for the rotor the drive must absolutely switch off during the run-up.

Switch-off weights of the different rotors:

Rotor	Switch-off weight
1711	5 g
1713	27 g
1717	20 g
1720	15 g
1721	15 g
1724	15 g
1725	19 g
1726	15 g

Rotor	Switch-off weight
1748	27 g
1754	15 g
1760	15 g
1789	5 g
1792	27 g
1794	15 g
1797	15 g
1798	15 g



The setting of the imbalance switch-off is only possible if the rotor is at standstill.

It is at any time possible to terminate the procedure by pressing the **STOP / OPEN** key. In this case the adjustments are not saved.

Action	Display / Comment
1. Keep the START key and the STOP / OPEN key pressed and switch on the mains switch at the same time.	→ *** Select Menu ***
2. Press the PROG key so often until the following will be displayed:	→ -> Imbalance
3. Press the START key.	→ e.g. Imbal corr = 100 Adjusted value of the imbalance switch-off. Default = 100
• Turn the control knob \odot .	→ e.g. Imbal corr = 100 The imbalance switch-off can be readjusted in increments of 1 within the range of – 40 to + 30. Increase the value: Switch-off takes place with a higher weight. Decrease the value: Switch-off takes place with a lower weight.
4. Press the START key.	→ Store Imbal corr ... The setting will be stored. → -> Imbalance
5. To exit the menu press the STOP / OPEN key twice.	→ *** Select Menu *** → e.g. 6 20 9/ 9 4000 5:20 Display of the centrifugation data.
6. Check the imbalance switch-off by a test run with the switch-off weight specified for the rotor.	

7.16 Set the transmission rate (baud rate) of the serial interface

The transmission rate (baud rate) of the serial interface can be adjusted.



The setting of the transmission rate (baud rate) of the serial interface is only possible if the rotor is at standstill.

It is at any time possible to terminate the procedure by pressing the **STOP / OPEN** key. In this case the adjustments are not saved.

Action	Display / Comment
1. Keep the START key and the STOP / OPEN key pressed and switch on the mains switch at the same time.	→ *** Select Menu ***
2. Press the PROG key so often until the following will be displayed:	→ -> Setup
3. Press the START key.	→ OEM Version = off/on
4. Taste PROG so oft drücken, bis folgende Anzeige erscheint:	→ Baudrate = 9600/19200 Transmission rate (baud rate) of the serial interface. Default = 9600
• Turn the control knob \odot .	→ Baudrate = 9600/19200 Set 9600 or 19200.
5. Press the START key.	→ Store Setup ... The setting will be stored.
	The changed transmission rate becomes only effective after a MAINS RESET.
	→ -> Setup
6. To exit the menu press the STOP / OPEN key twice.	→ *** Select Menu *** → e.g. 6 20 9/9 4000 5:20 Display of the centrifugation data.

7.17 Function test

The individual components of the centrifuge can be tested on its function.















The function test is only possible if the rotor is at standstill























In order to be able to check the function of the two speed sensors the lid must be opened before starting the function test.



In the menu "Test" it is possible to jump back to the parameter indicated before by pressing the $\overline{T/^{\circ}C}$ key.

It is at any time possible to terminate the procedure by pressing the \odot STOP / OPEN \odot key.





Action	Display / Comment
1. Keep the \odot START key and the \odot STOP / OPEN \odot key pressed and switch on the mains switch at the same time.	→ *** Select Menu ***
2. Press the \overline{PROG} key so often until the following will be displayed:	→ -> Test
3. Press the \odot START key.	→ e.g. 00 Software Version = 01.01 Program version
4. Press the \overline{PROG} key.	→ 01 Display Full <-> Blank
<ul style="list-style-type: none"> • Turn the control knob \odot one step to the left. 	→  Function test of the LC-display. All segments of the display light up.
<ul style="list-style-type: none"> • Turn the control knob \odot one step to the right. 	→ All segments of the display deactivated (no display)
5. Press the \overline{PROG} key.	→ e.g. 02 Imbal act = 1 : 0 max = 3 : 4 imbalance values. act = actual X- and Y-value in per cent of the imbalance sensor. max = actual X- and Y-value in per cent of the imbalance sensor.
	 Function test of the imbalance sensor: Shake the motor by hand. The current X- and Y-values must changed.

Action	Display / Comment
6. Press the PROG key.	<p>→ 03 RPM Rot = 0 Mot = 0 Speed Rot = Speed value of the speed sensor (B4) on top of the motor. Mot = Speed value of the speed sensor (B2.1) at the bottom of the motor.</p> <p> Function test of the speed sensors: Turn the rotor by hand. Speed values must be displayed.</p>
7. Press the PROG key.	<p>→ 04 LEDs off Function test of the light emitting diodes (LED) in the keys. All LEDs are off.</p> <ul style="list-style-type: none"> • Turn the control knob  one step to the right. → 04 LED Stop on Right LED in the STOP / OPEN key lights up. • Turn the control knob  one step to the right. → 04 LED Open on Left LED in the STOP / OPEN key lights up. • Turn the control knob  one step to the right. → 04 LED Start on LED in the START key lights up. • Turn the control knob  one step to the right. → 04 LED Precool on LED in the  key lights up. • Turn the control knob  one step to the right. → 04 LED RCF on LED in the RCF key lights up. • Turn the control knob  one step to the right. → 04 LED Prog on Has no function with ROTINA 380 / 380 R since the PROG key has no LED.
8. Press the PROG key.	<p>→ 05 Press any key Function test of the keys. Press the keys of the operating panel successively.</p> <p> Each key must be pressed once. In order to jump over the function test of the keys turn the control knob  one step to the right.</p>
9. Press the PROG key.	<p>→ 05 Key Prog PROG key functions.</p>

Action	Display / Comment
10. Press the  key.	→ 05 Key Temp  key functions.
11. Press the  key.	→ 05 Key Acc/Dec  key functions.
12. Press the  key.	→ 05 Key RCF  key functions.
13. Press the  key.	→ 05 Key RPM  key functions.
14. Press the  key.	→ 05 Key Time  key functions.
15. Press the  key.	→ 05 Key Stop  key functions.
16. Press the  key.	→ 05 Key Precool  key functions.
17. Press the  key.	→ 05 Key Start  key functions. → *** o.k. *** Appears only if all keys on the operating panel were pressed and have function.  If a key should not function, then the control knob  must be turned one step to the right, so that the function test can be continued.
18. Press the  key.	→ 06 Error LED off Function test of the yellow error LED of the control-processor on the electronics (A1).
<ul style="list-style-type: none"> • Turn the control knob  one step to the right. 	→ 06 Error LED on The yellow error LED lights up.
19. Press the  key.	→ 07 Sound / Bell off Function test of the acoustic beeper.
<ul style="list-style-type: none"> • Turn the control knob  one step to the right. 	→ 07 Sound / Bell on The acoustic beeper on the operating panel will be activated.

Action	Display / Comment
20. Press the PROG key.	→ 08 Closure Motor off Function test of the motor of the lid lock.
• Turn the control knob \odot one step to the right.	→ 08 Closure Motor on The motor of the lid lock will be activated.  If OPEN / OEFFNEN is displayed after completion of the function test, then the ◀ key must be pressed that the motor-driven lid lock assumes again the normal position (opened).
21. Press the PROG key.	→ e.g. 09 LI (KI¹⁾) = 0 Lr (Kr¹⁾) = 0 Mo = 1 Mc = 0 0 = Switch not actuated. 1 = Switch actuated. LI (KI ¹⁾) = Lid lock, Lid switch for left hook. Lr (Kr ¹⁾) = Lid lock, Lid switch for right hook. Mo = Position switch "Mo" of the motor-driven lid lock for position "lid opened". Mc = Position switch "Mc" of the motor-driven lid lock for position "lid closed".  Function test of the lid switches for the hooks: Close the lid. KI and Kr must indicated 1.
22. Press the PROG key.	→ e.g. 10 T Cond (Kond¹⁾) = 26°C = 2996mV Temperature value of the temperature sensor (B3) at the condenser.
23. Press the PROG key.	→ e.g. 11 T Lid (Deckel¹⁾) = --- Temperature value of the temperature sensor (B2) at the top of the centrifuge chamber. Does not exist in ROTINA 380 R.
24. Press the PROG key.	→ e.g. 12 T Chamb. (Kessel¹⁾) = 26°C = 2996mV Temperature value of the temperature sensor (B1) at the bottom of the centrifuge chamber.
25. Press the PROG key.	→ e.g. 13 T Out = 21°C = 1212mV Temperature value of the temperature sensor in the imbalance sensor (B2.2).
26. Press the PROG key.	→ e.g. 14 T Amb = 29°C = 2272mV Temperature value of the temperature sensor on the electronics (A1).

1) with Software < V 01.04

Action	Display / Comment
27. Press the PROG key.	→ e.g. 15 T IR = --- Temperature value of an external sensor (does not exist in ROTINA 380 / 380 R).
28. Press the PROG key.	→ e.g. 16 T ext = --- Temperature value of an external sensor (does not exist in ROTINA 380 / 380 R).
29. Press the PROG key.	→ e.g. 17 Keylock = 3 (2¹) = 3300 mV Position of the key-operated switch. Tolerance: ± 250 mV.
30. Press the PROG key.	→ e.g. 18 FC State (Status¹) = 8040 State of the frequency converter.
31. Press the PROG key.	→ e.g. 19 FC Temp. = 25°C Temperature in the frequency converter.
32. Press the PROG key.	→ e.g. 20 FC Volt. = 329 V Value of the intermediate circuit voltage.
33. Press the PROG key.	→ 21 Cooling unit off Function test of the compressor.
<ul style="list-style-type: none"> • Turn the control knob  one step to the right. 	→ 21 Cooling unit on Compressor switched on.  Caution! The fan is <u>not</u> working and the temperature of the condenser will <u>not</u> be checked! Do not switch on the compressor longer than 5 seconds. The time between switching off and switching on the compressor again <u>must</u> be minimum 1 minute!
34. Press the PROG key.	→ 22 Relay (Relais¹) Heater off Function test of the relay for the heating.
<ul style="list-style-type: none"> • Turn the control knob  one step to the right. 	→ 22 Relay (Relais¹) Heater on Relay for the heating is switched on.  Risk of burning! The surface temperature of the heating element in the centrifuge chamber of the centrifuge can be up to 500°C / 932°F. Do not touch the heating element. Do not switch on the heating longer than 5 seconds.

1) with Software < V 01.04

Action	Display / Comment
35. Press the PROG key.	→ 23 Relay (Relais ¹⁾) MV1 off Function test of the relay for the fan. Relay and fan exists only in ROTINA 380 R / 380 RH.
• Turn the control knob \odot one step to the right.	→ 23 Relay (Relais ¹⁾) MV1 on Relay for the fan for cooling the motor is switched on.
36. Press the PROG key.	→ 24 Relay (Relais ¹⁾) MV2 off Function test of the relay for solenoid valve 2.
• Turn the control knob \odot one step to the right.	→ 24 Relay (Relais ¹⁾) MV2 on Relay for solenoid valve 2 is switched on.
37. Press the PROG key.	→ 25 Relay (Relais ¹⁾) Res off Function test of the spare relay.
• Turn the control knob \odot one step to the right.	→ 25 Relay (Relais ¹⁾) Res on Spare relay is switched on (by default not equipped).
38. Press the PROG key.	→ e.g. 26 Mains Sync = 50 Hz Mains synchronisation
39. Press the PROG key.	→ 27 Cooling Fan Power = 0 % Function test of the fan at the condenser.
• Turn the control knob \odot to the right.	→ e.g. 27 Cooling Fan Power = 40 % Fan at the condenser is switched on. The speed is adjustable between 30% and 95%.
40. Press the PROG key.	→ e.g. 28 Machine Type = 00 Machine type is displayed.
41. Press the PROG key.	→ e.g. 29 Cooling Version = 0F Cooling version is displayed. 0F = ROTINA 380 R 08 = ROTINA 380
42. To exit the menu press the STOP / OPEN key three times.	→ -> Test → *** Select Menu *** → e.g. 6 20 9/ 9 4000 5:20 Display of the centrifugation data.

1) with Software < V 01.04

7.18 Delete programs and program linking



The deletion of programs and program linking is only possible if the rotor is at standstill.



The deletion of individual programs or program linking is not possible. Always all programs or program linking are set back to default values.

It is at any time possible to terminate the procedure by pressing the **STOP / OPEN** key.

Action

Display / Comment

- | Action | Display / Comment |
|----------------------------------------------------------------------------------------------------------------------|-------------------------------------------------------------------------------------------------------------------------------------------------------------------------|
| 1. Keep the START key and the STOP / OPEN key pressed and switch on the mains switch at the same time. | → *** Select Menu *** |
| 2. Press the PROG key so often until the following will be displayed: | → -> Eeprom |
| 3. Press the START key. | → Eeprom Read |
| 4. Press the PROG key so often until the following will be displayed: | → Erase Single Progs no or Erase Multi Progs no
Single Progs = Programs.
Multi Progs = Program linking. |
| |  It is possible to jump back to the previous display by pressing the T/C key. |
| • Turn the control knob \odot one step to the right. | → Erase Single Progs yes or Erase Multi Progs yes
no = Do not delete programs or program linking.
Yes = Delete programs or program linking. |
| 5. Press the START key. | → Are you sure ? no
Repeated confirmation. |
| • Turn the control knob \odot one step to the right. | → Are you sure ? yes
no = Do not delete Programs or program linking.
Yes = Delete Programs or program linking. |
| 6. Press the START key. | → -> Eeprom |





Action	Display / Comment
7. Press the  key.	→ *** Select Menu ***
8. Press the  key.	→ EE INIT : Single Prog : 99 or EE INIT : Multiple Prog : 24 All programs or program linking are deleted and afterwards the "Select Menu" will be terminated. e.g. ROTINA 380 R → Centrifuge model e.g. V 01.01 → Program version e.g. Rotor 4 Nmax=4500 R=184 → Rotor information e.g. 6 20 9/9 4000 5:20 → Display of the centrifugation data.



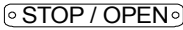

7.19 Display the contents of the memory cells of the EEPROM



The display of the contents of the EEPROM-memory cells is only possible if the rotor is at standstill.

It is at any time possible to terminate the procedure by pressing the  key.

Action	Display / Comment
1. Keep the  key and the  key pressed and switch on the mains switch at the same time.	→ *** Select Menu ***
2. Press the  key so often until the following will be displayed:	→ -> Eeprom
3. Press the  key.	→ Eeprom Read
4. Press the  key.	→ e.g. Adr: 0000 = 00000000 - 00000009 Content of the memory cells 00, 02, 04, 06, 08, 0A, 0C, 0E. Example: Content of the address 0E = 09

Action	Display / Comment
<ul style="list-style-type: none"> Turn the control knob  to the right. 	<p>→ e.g. Adr: 0010 = 000003E3 - 00000215 Content of the memory cells 10, 12, 14, 16, 18, 1A, 1C, 1E. Example: Content of the address 16 = E3 By turning the control knob  the contents of the memory cells 0000 up to 7FF0 can be displayed.</p> <p> If the control knob  is turned to the right and the (PROG) key is pressed at the same time then the address will change in steps of 1000_{hex}.</p>
<p>5. To exit the menu press the (STOP / OPEN) key four times.</p>	<p>→ Eeprom Read → -> Eeprom → *** Select Menu *** → e.g. 6 20 9/∧ 9 4000 5:20 Display of the centrifugation data.</p>

7.20 Initialise the EEPROM



If the EEPROM is initialized, the centrifuge model, the setting of the imbalance switch-off and the offset values of the temperature sensors are deleted. The centrifuge model, the offset-values and the imbalance switch-off must be set again after the initialization. Recommendation: Note the adjusted imbalance value and the offset-values of the temperature sensors before initializing and enter afterwards again.

The initialisation of the EEPROM is only possible if the rotor is at standstill.

It is at any time possible to terminate the procedure by pressing the **(STOP / OPEN)** key.

Action	Display / Comment
<p>1. Keep the (START) key and the (STOP / OPEN) key pressed and switch on the mains switch at the same time.</p>	<p>→ *** Select Menu ***</p>
<p>2. Press the (PROG) key so often until the following will be displayed:</p>	<p>→ -> Eeprom</p>
<p>3. Press the (START) key.</p>	<p>→ Eeprom Read</p>

Action	Display / Comment
4. Press the PROG key so often until the following will be displayed:	→ EE Init Global Data no
• Turn the control knob \odot one step to the right.	→ EE Init Global Data yes no = Do not initialise the EEPROM. yes = Initialise the EEPROM.
5. Press the START key.	→ Are you sure ? no Repeated confirmation.
• Turn the control knob \odot one step to the right.	→ Are you sure ? yes no = Do not initialise the EEPROM. yes = Initialise the EEPROM.
6. Press the START key.	→ -> Eeprom
7. Press the STOP / OPEN key.	→ *** Select Menu ***
8. Press the STOP / OPEN key.	→ EE INIT : Global Data ... The EEPROM is initialised and afterwards the "Select Menu" will be terminated.
	→ e.g. ROTINA 380 R Centrifuge model
	→ e.g. V 01.01 Program version
	→ e.g. Rotor 4 Nmax=4500 R=184 Rotor information
	→ e.g. 6 20 9/∧ 9 4000 5:20 Display of the centrifugation data.

7.21 Automatic repetition of the centrifugation run

For test purposes the automatic repetition of the centrifugation run can be selected.

The number of centrifugation runs is counted automatically.



The break time between the centrifugation runs can be set.

This automatic repetition remains activated until the test run is terminated or the centrifuge will be switched off.



The setting is only possible if the rotor is at standstill.

It is at any time possible to terminate the procedure by pressing the **STOP / OPEN** key.

Action	Display / Comment
1. Keep the START key and the STOP / OPEN key pressed and switch on the mains switch at the same time.	→ *** Select Menu ***
2. Press the PROG key so often until the following will be displayed:	→ -> Cont Run
3. Press the START key.	→ T/break = 0:00 Break between the centrifugation runs.
<ul style="list-style-type: none"> • Turn the control knob \odot. 	→ e.g. T/break = 1:30 Set the break time. It is settable from 1 second to 9 minutes and 59 seconds, in 1 second increments.
4. Press the START key.	→ e.g. T/break = 1:30 The break time is temporarily stored.  If the number of the performed centrifugation runs should not be indicated or deleted, continue with step 7.
5. Press the PROG key.	→ e.g. Run# = 5 Start=Clear Number of the carried out centrifugation runs of the last test run.  If the number of the performed centrifugation runs should not be deleted, continue with step 7.
6. Press the START key.	→ # Runs cleared !!! The number of the carried out centrifugation runs is deleted. → e.g. T/break = 1:30 Break between the centrifugation runs.
7. To exit the menu press the STOP / OPEN key three times.	→ -> Cont Run → *** Select Menu *** → e.g. 6 20 9/ 9 4000 5:20 Display of the centrifugation data.
8. Enter the centrifugation parameters.	→ e.g. 6 20 9/ 9 3000 1:00
9. Close the lid.	→ e.g. 6 20 9/ 9 3000 1:00

10. Press the **START** key. → e.g. **6 20 9/9 3000 1:00**
Test run with automatic repetition of the centrifugation run is carried out.
11. Press the **STOP / OPEN** key during the break time to terminate the test run. → e.g. **Run# 5 t break = 0:34**
The test run is terminated and the lid opens.
- e.g. **6 20 9/9 3000 1:00**
Display of the centrifugation data.
The automatic repetition of the centrifugation run is deleted.

8 Update the software of the control processor

For the update of the software of the control-processor a PC, the flash-program "HettichFlash" and an interface cable is needed.

The flash-program "HettichFlash" and the interface cable (cat. no. E2908) are available as accessories.

8.1 Install the flash-program on the PC

1. Start the installation program "setup.exe" by double click with the mouse.
2. Follow the instructions of the installation program. The installation program gives information about all necessary installation steps and sets up the program on the PC.

On the desktop the "HettichFlash" symbol will be generated.

8.2 Perform a software update



After a software update the centrifuge model, the setting of the imbalance switch-off and the offset values of the temperature sensors are deleted. The centrifuge model, the offset values and the imbalance switch-off must be set again after the update.

Recommendation: Note the set imbalance value and the offset values of the temperature sensors before the software update and enter it again after the update.

1. Remove the front panel as described in chapter 11.1, pg. 81.
2. Plug the jumper on the electronics (A1) at position "programming", see Fig. 1.
3. Plug on the interface cable on the electronics (A1), see Fig. 1, a.
4. Connect the interface cable with the PC.
5. Connect the centrifuge to the mains supply again and switch on the mains switch.
6. Store the file with the actual software version of the control-processor e.g. "Rotina380_V01_03.H86" on the PC.
7. On the desktop double click on the "HettichFlash" symbol.

8. Click on the button "Connect to target".
The connection to the centrifuge is made and "bootstrap-loader finished" is displayed.
9. Click on the button "Open HexFile" to open the window "Öffnen".
If the connection to the centrifuge was made the first time, the window "Öffnen" appears automatically.
10. Select the file with the actual software version of the control-processor e.g. "Rotina380_V01_03.H86" and then click on the button "Öffnen".
11. Check in the left program window that the desired file name e.g. "H386 File = Rotina380_V01_03.H86" and the desired software version e.g. "SW Version = V 01.03-09" is displayed.
12. Click on the button "Program Flash". The progress of the update is indicated with a bar line display and a counter.
After successful update "flashprogramming successful completed" is displayed.
13. Click on the button "Exit" to exit the program.
14. Switch off the mains switch and disconnect the centrifuge from the mains supply.
15. Pull out the interface cable from the electronics (A1).
16. Plug the jumper on the electronics (A1) again at position "normal position", see Fig. 1.
17. Mount the front panel again.

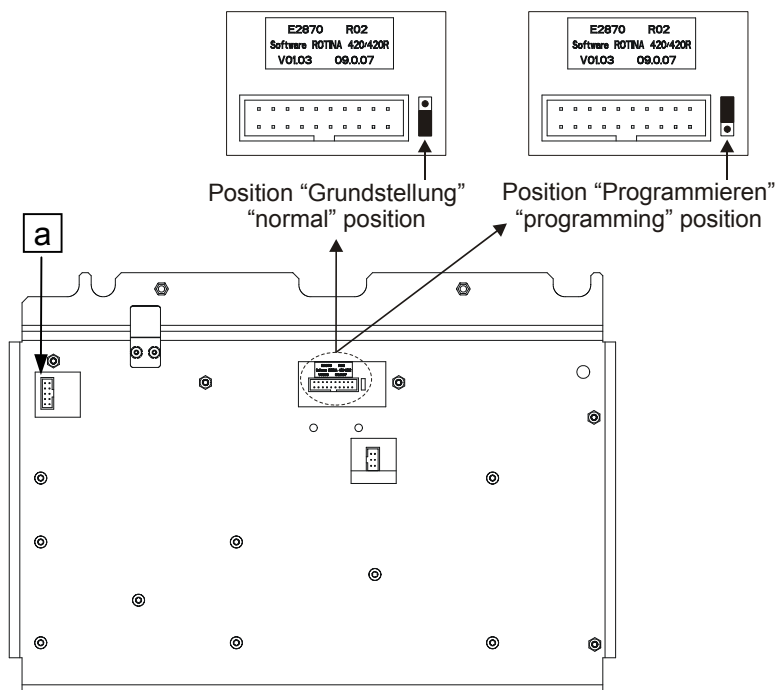

Fig. 1

9 Functional check after a repair

After a repair a functional check of the unit must be carried out.

For functional check a test run with the loaded rotor must be performed.

During the test run the followings must be checked:

- Function of the keys, the display and the LEDs.
- Run-up and slow-down time, max. speed of the rotor. Values see operating instructions chapter "Anhang/Appendix, Rotoren und Zubehör/Rotors and accessories".
- Sample temperature. Values see operating instructions chapter "Anhang/Appendix, Rotoren und Zubehör/Rotors and accessories".
- Imbalance switch-off. Values see repair instructions pg. 60, chapter 7.15.3.
- Current consumption. Values see repair instructions pg. 98, chapter 12.4.

After the test run a safety test must be carried out. Check the following values:

- Insulation resistance > 2 M Ω
 - Protective conductor resistance < 0.2 Ω
 - Leakage current < 3.5 mA *
- * limit according to EN 61010-1

A laboratory centrifuge do not belong to those medical appliances which may be tested according to the regulation IEC 60601-1 or corresponding national medical electronic standards. Laboratory centrifuges are classified as laboratory equipment.

The regulations applying to laboratory equipment are IEC 61010-1 or European standard EN 61010-1.

10 General arrangement of the components

Item	Designation
1	Lid
2	Lid inner cover ROTINA 380
3	Lid inner cover ROTINA 380 R
4	Hinge
5	Pneumatic spring
6	Packing ring
7	Front panel ROTINA 380
8	Front panel ROTINA 380 R
9	Operating panel - electronics
10	Rotary encoder with cable
11	Rotary knob with flat spring
12	Motor cover
13	Motor Folded bellow (only ROTINA 380 R)
14	Motor
15	Speed sensor (on top of the motor)
16	Speed/imbalance sensor (at the bottom of the motor)
17	Rubber-metal bearing
18	Anti-twist device
19	Appliance plug with radio interference suppression filter (only ROTINA 380 / 380 R, 230 V version)
20	Appliance plug with radio interference suppression filter (only ROTINA 380 / 380 R, 120 V version)
21	ON-OFF switch (only ROTINA 380, 230 V version)
22	ON-OFF switch (only ROTINA 380, 120 V version)
23	ON-OFF switch (only ROTINA 380 R, 230 V version)
24	ON-OFF switch (only ROTINA 380 R, 120 V version)
25	Transformer (only ROTINA 380 / 380 R, 120 V version)
26	Circuit breaker (only ROTINA 380 / 380 R, 120 V version)
27	Electronics ROTINA 380
28	Electronics ROTINA 380 R
29	Supporting sheet for Electronics
30	Flat ribbon cable (20-pole)
31	Brake resistor with overtemperature switch
32	Ventilation duct (only ROTINA 380)
33	Compressor (only ROTINA 380 R, 230 V version)
34	Compressor (only ROTINA 380 R, 120 V version)
35	Starting relay (only ROTINA 380 R, 230 V version)
36	Starting relay (only ROTINA 380 R, 120 V version)
37	Starting capacitor (only ROTINA 380 R, 230 V version)
38	Starting capacitor (only ROTINA 380 R, 120 V version)
39	Temperature sensor (B1) in the centrifuge chamber (only ROTINA 380 R)
40	Temperature sensor (B3) at the condenser (only ROTINA 380 R)
41	Fan at the condenser (only ROTINA 380 R)
42	Fan for cooling the motor (only ROTINA 380 R)
43	Ventilation grille
44	Rubber foot
45	Right lid lock complete
46	Eccentric disc
47	Contact spring
48	Sliding block
49	Left lid lock complete
50	Tension spring
51	Connecting rod

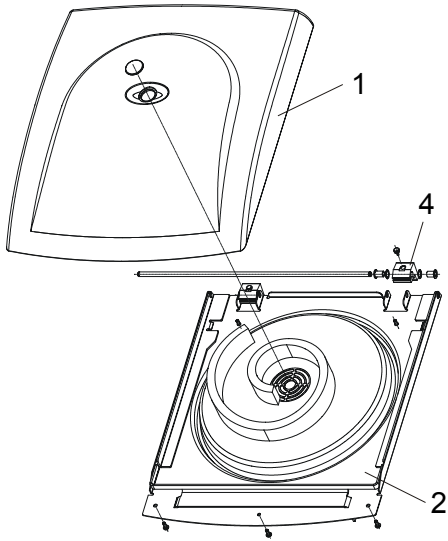

Fig. 2

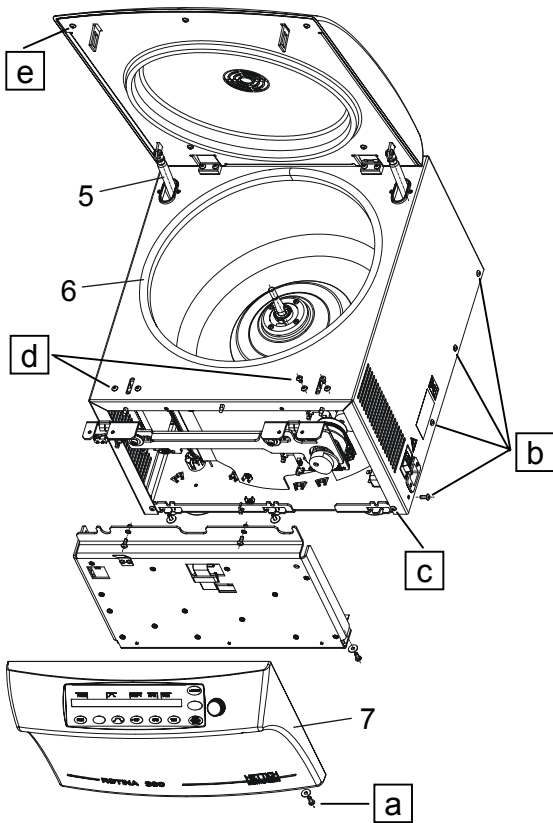

Fig. 3

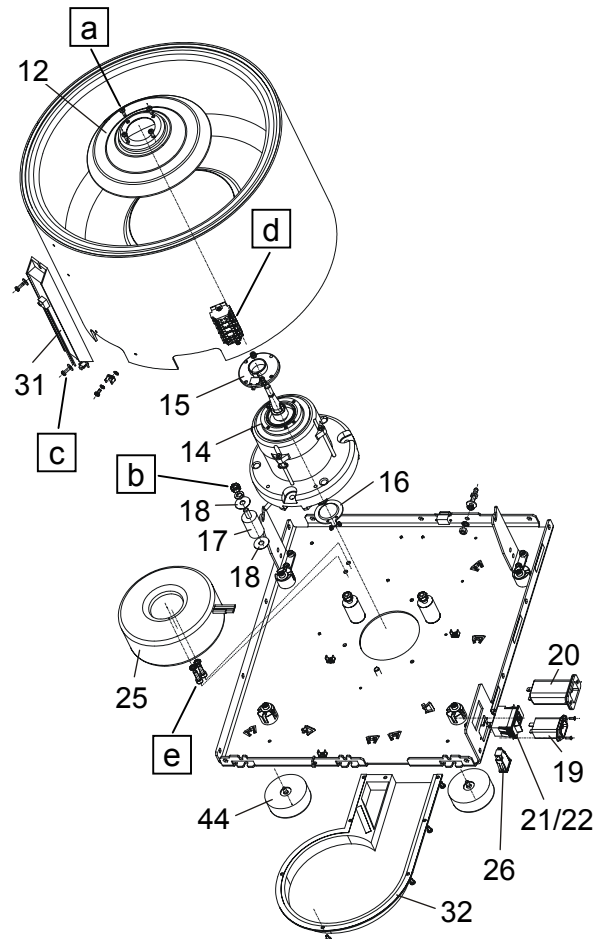

Fig. 4

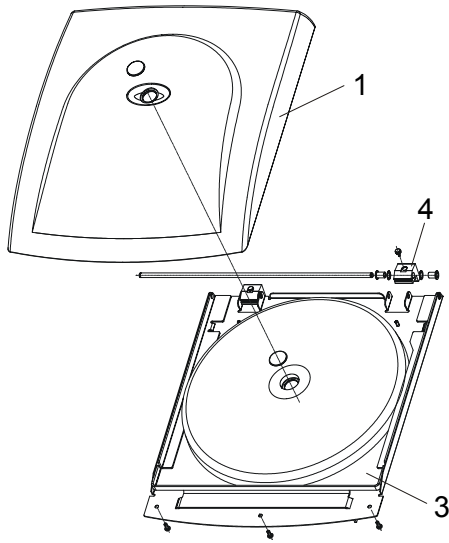

Fig. 5

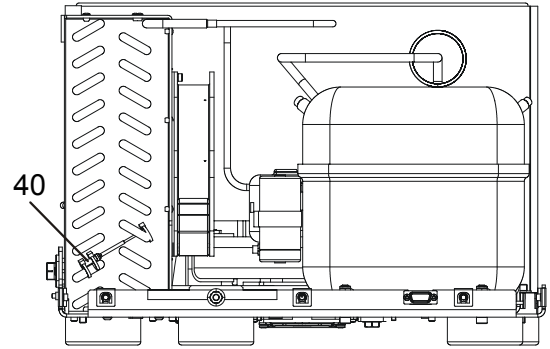

Fig. 6

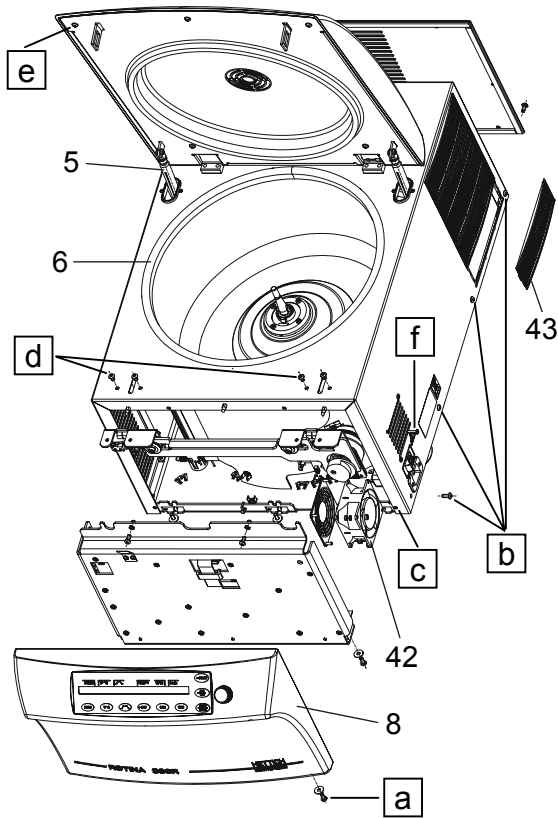

Fig. 7

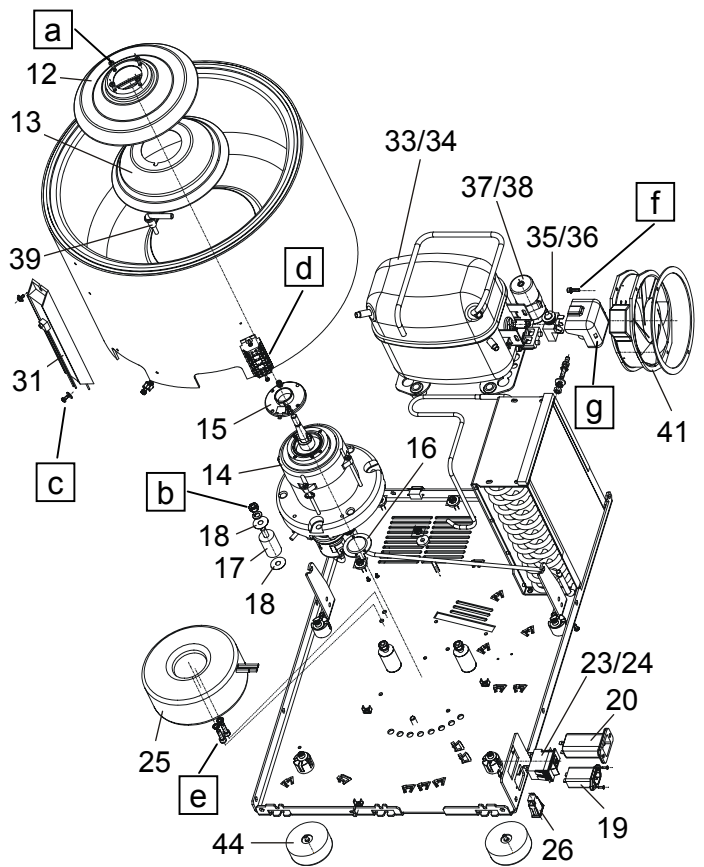

Fig. 8

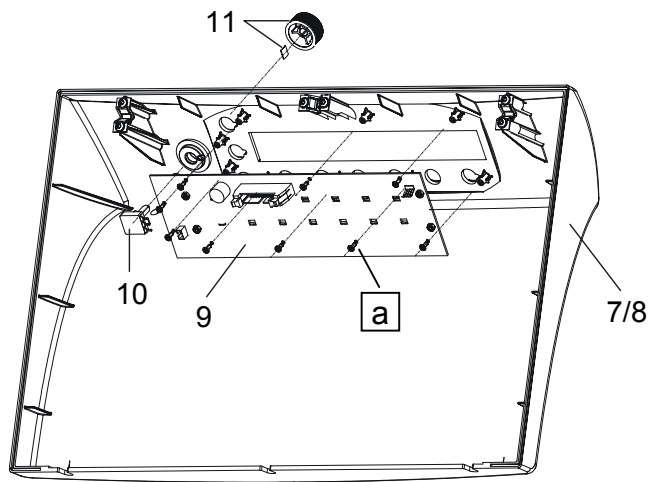

Fig. 9

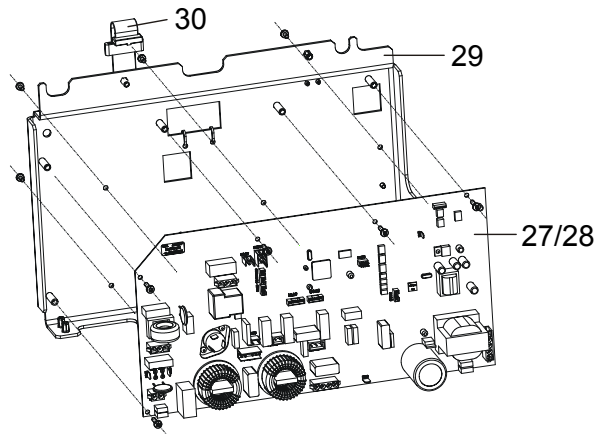

Fig. 10

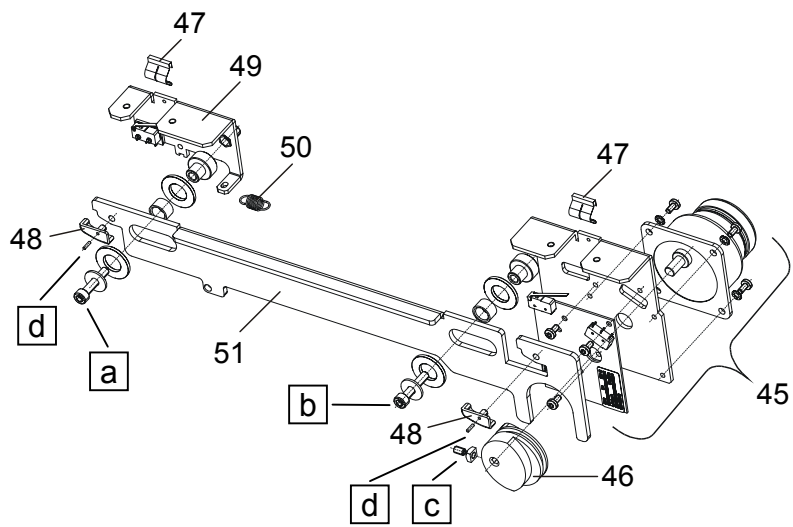

Fig. 11

11 Mounting and removing components



Before mounting and removing components the mains switch must be switched off and the centrifuge must be disconnected from the mains supply.

11.1 Removing the front panel

- Open the lid.
- Switch off the mains switch and disconnect the centrifuge from the mains supply.
- Unscrew the 3 screws (pg. 78, Fig. 3, a ; pg. 79, Fig. 7, a) on the lower part of the front panel.
- Pull the lower part of the front panel forward as far as it can be detached.
- Pull the flat ribbon cable on the operating panel (A2).
- Remove the front panel.
- To mount the front panel, carry out these steps in opposite order.



First press the lower part of the front panel against the housing and then the upper part until the 3 bolts will snap in.

11.2 Removing the support sheet of the electronics (A1)

- Remove the front panel as described in chapter 11.1, pg. 81.
- Unscrew the 2 screws (Fig. 12, a) at the top of the support sheet.
- Loosen the 3 screws (Fig. 12, b) on the lower part of the support sheet by approx. 1 mm.
- Take out the support sheet forward and hook it in horizontally on the centrifuge housing with the screws (Fig. 12, b ; Fig. 13, b), see Fig. 13.
- To mount the support sheet, carry out these steps in opposite order.

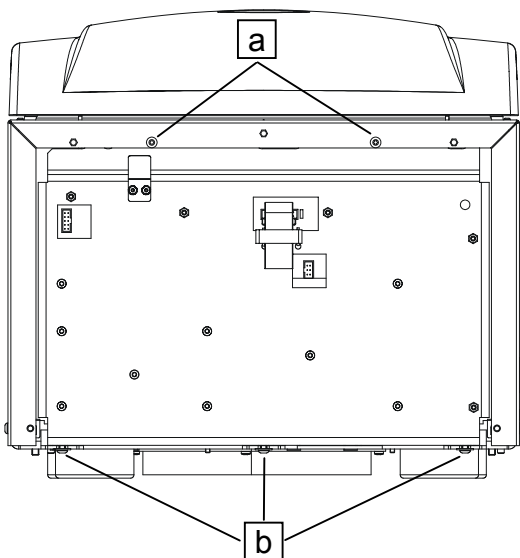

Fig. 12

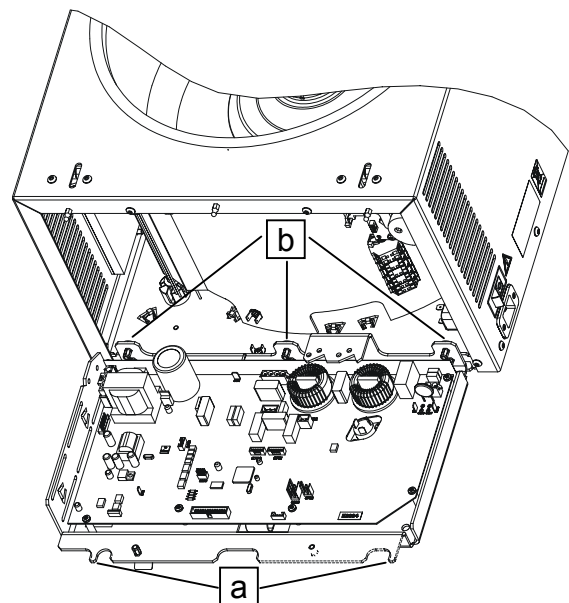

Fig. 13

11.3 Hook in the front panel at the support sheet for electronics (A1)



In order to perform electrical measurements at the centrifuge it is necessary to hook in the front panel at the support sheet for electronics (A1).

- Remove the front panel and the support sheet for electronics (A1) as described in chapters 11.1, 11.2, pg. 81.
- Plug the flat ribbon cable on the operating panel (A2) again.
- Hook in the front panel with the left and right spring clip (Fig. 14, a) on the two supporting devices (pg. 81, Fig. 13, a) at the support sheet for electronics (A1), see Fig. 14.

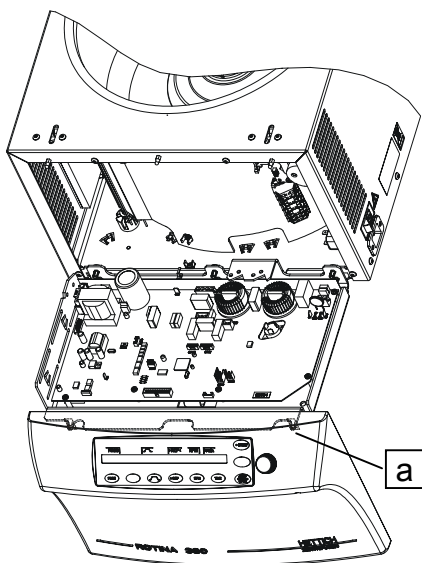

Fig. 14

11.4 Removing the upper part of the centrifuge housing



For removing the upper part of the centrifuge housing 2 persons are needed.

- Remove the front panel and the support sheet for electronics (A1) as described in chapters 11.1, 11.2, pg. 81.
- Pull both plugs S703 and S707 of the lid lock on the electronics (A1), see pg. 95, chapter 12.3.
- Remove all required fixations of the cables.
- Remove the rear panel.
- Remove both pneumatic springs as described in chapter 11.22, pg. 91.
- Unscrew the fastening screws of the upper part of the centrifuge housing. 4 screws (pg. 78, Fig. 3, b ; pg. 79, Fig. 7, b) each on the left and right side of the upper part of the housing and 1 screw (pg. 78, Fig. 3, c ; pg. 79, Fig. 7, c) each left and right on the front of the upper part of the centrifuge housing.
- Remove the upper part of the centrifuge housing and place it next to the centrifuge.
- To mount the upper part of the housing, carry out these steps in opposite order.

11.5 Removing Motor (M1) / Rubber-metal bearings / Speed sensor (B2.1, at the bottom of the motor) / Imbalance sensor (B2.2)

- Remove the front panel and the support sheet for electronics (A1) as described in chapters 11.1, 11.2, pg. 81.
- Pull the plugs S104 and S701 on the electronics (A1), see pg. 95, chapter 12.3.
- Remove all required fixations of the cables.
- Dismount the rotor.
- Undo the 4 screws (pg. 78, Fig. 4, a ; pg. 79, Fig. 8, a) on the motor cover and remove the motor cover.
- In centrifuges with cooling, remove the rubber packing (pg. 79, Fig. 8, item 13) between the motor cover and the centrifuge chamber.
- Unscrew the speed sensor (pg. 78, Fig. 4, item 15 ; pg. 79, Fig. 8, item 15) from the upper end plate of the motor (2 screws) and place it in the centrifuge chamber.
- Unscrew the 3 nuts (pg. 78, Fig. 4, b ; pg. 79, Fig. 8, b) on the lower end plate of the motor.
- Take out the motor from the centrifuge from above.
- Unscrew the speed sensor / imbalance sensor (pg. 78, Fig. 4, item 16 ; pg. 79, Fig. 8, item 16) at the bottom of the motor (3 screws).
- Before mounting the motor, check the 3 rubber-metal bearings for possible wear or cracks and replace them if necessary.
If one rubber-metal bearing is damaged all 3 rubber-metal bearings must be replaced.
While mounting the rubber-metal bearings, make sure that there is an anti-twist device (pg. 78, Fig. 4, item 18 ; pg. 79, Fig. 8, item 18) on both sides of the bearing to prevent it from turning.
- To mount the motor, carry out these steps in opposite order.
- After exchanging the motor or the rubber-metal bearings the imbalance switch-off must be checked, see pg. 60, chapter 7.15.3.

11.6 Speed sensor (B4, on top of the motor)

- Remove the front panel and the support sheet for electronics (A1) as described in chapters 11.1, 11.2, pg. 81.
- Pull the plug S602 on the electronics (A1), see pg. 95, chapter 12.3.
- Dismount the rotor.
- Undo the 4 screws (pg. 78, Fig. 4, a ; pg. 79, Fig. 8, a) on the motor cover and remove the motor cover.
- In centrifuges with cooling, remove the rubber packing (pg. 79, Fig. 8, item 13) between the motor cover and the centrifuge chamber.
- Remove the fixation of the speed sensor cable.
- Unscrew the speed sensor (pg. 78, Fig. 4, item 15 ; pg. 79, Fig. 8, item 15) from the upper end plate of the motor (2 screws).
- To mount the speed sensor, carry out these steps in opposite order.

11.7 Motor-driven lid lock



All plastic parts on the motor-driven lid lock are wearing parts and must be replaced if they are worn out.

11.7.1 Removing the motor-driven lid lock

- Remove the front panel and the support sheet for electronics (A1) as described in chapters 11.1, 11.2, pg. 81.
- Pull the plugs S703 and S707 on the electronics (A1) see pg. 95, chapter 12.3.
- Unscrew the two screws (pg. 78, Fig. 3, d ; pg. 79, Fig. 7, d) each on the left and right lid lock on the upper part of the centrifuge housing and remove the lid lock.
- To mount the motor-driven lid lock, carry out these steps in opposite order.

11.7.2 Replacing the left lid lock

- Remove the lid lock as described in chapter 11.7.1.
- Suspend the tension spring (pg. 80, Fig. 11, item 50) on one side.
- Remove all fixations of the two cables at the left and the right lid lock and unplug the plug on the right lid lock.
- Unscrew the fastening screw (pg. 80, Fig. 11, a).
- Exchange the left lid lock.
- Assemble in opposite order.

11.7.3 Replacing the right lid lock

- Remove the lid lock as described in chapter 11.7.1.
- Remove all fixations of the two cables at the right lid lock and unplug the plug on the right lid lock.
- Use the hexagon pin driver to turn the eccentric disc (pg. 80, Fig. 11, item 46) until the hexagon socket points upwards.
- Unscrew the fastening screw (pg. 80, Fig. 11, b).
- Exchange the right lid lock.
- Assemble in opposite order.

11.7.4 Replacing the eccentric disc

- Remove the lid lock as described in chapter 11.7.1, pg. 84.
- Remove the right lid lock as described in chapter 11.7.3, pg. 84.
- Loosen the hexagon socket screw (pg. 80, Fig. 11, c) down on the eccentric disc (pg. 80, Fig. 11, item 46).
- Remove the eccentric disc (pg. 80, Fig. 11, item 46) from the motor axis.
- Push the new eccentric disc as far as it will go on the motor axis and tighten the hexagon socket screw on the eccentric disc.
- Assemble in opposite order.

11.7.5 Replacing the sliding blocks

- Remove the lid lock as described in chapter 11.7.1, pg. 84.
- Use the hexagon pin driver to turn the eccentric disc (pg. 80, Fig. 11, item 46) until the hexagon socket points upwards.
- Unscrew the two fastening screws (pg. 80, Fig. 11, a and b) and remove the connecting rod (pg. 80, Fig. 11, item 51).
- Push the steel pin (pg. 80, Fig. 11, d) from behind out of the sliding block (pg. 80, Fig. 11, item 48) using a suitable tool.
- Remove the sliding block (pg. 80, Fig. 11, item 48).
- Put on the new sliding block.
- Carefully drive the steel pin (pg. pg. 80, Fig. 11, d) from the front into the borehole of the sliding block (pg. 80, Fig. 11, item 48) with a hammer.
- Assemble in opposite order.

11.8 Electronics (A1)



Wait at least 2 minutes after disconnecting the centrifuge from the mains, until the intermediate circuit capacitor of the frequency converter is discharged.

- Remove the front panel as described in chapter 11.1, pg. 81.
- Unscrew the 9 fastening screws (Fig. 15, a) of the electronics (A1) at the support sheet.
- Remove the support sheet for electronics (A1) as described in chapter 11.2, pg. 81.
- Unplug all the plugs on the electronics (A1).
- Unscrew the 5 fastening screws (Fig. 16, a) on the electronics (A1).
- Remove the electronics (A1).
- To mount the electronics (A1), carry out these steps in opposite order.

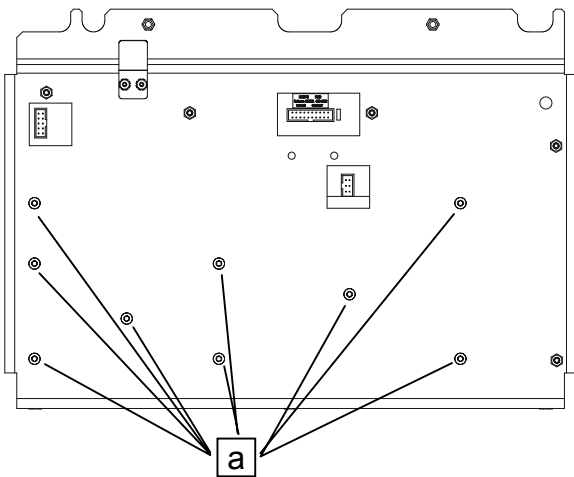

Fig. 15

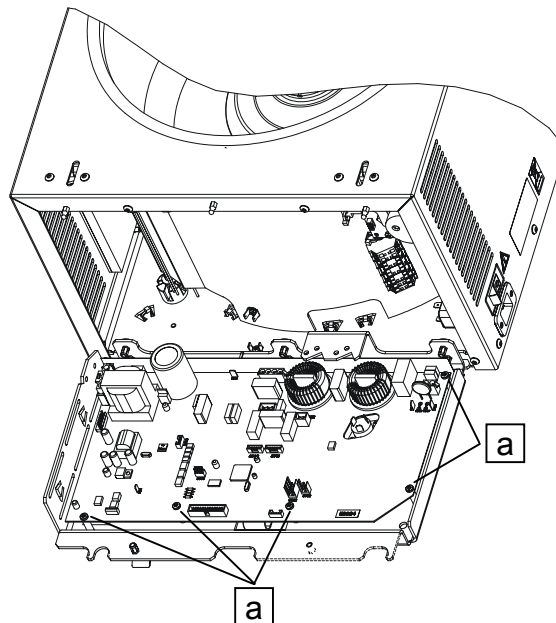

Fig. 16

11.9 Operating panel (A2)

- Remove the front panel as described in chapter 11.1, pg. 81.
- Unplug the cable of the rotary encoder (S1) on the operating panel.
- Unscrew the 9 fastening screws (pg. 80, Fig. 9, a) and then remove the printed circuit board (pg. 80, Fig. 9, item 9).
- To mount the operating panel (A2), carry out these steps in opposite order.

11.10 Rotary encoder (S1)

- Remove the front panel as described in chapter 11.1, pg. 81.
- Pull the rotary knob (pg. 80, Fig. 9, item 11).
- Unplug the cable of the rotary encoder (S1) on the operating panel.
- Unscrew the hexagonal nut at the rotary encoder (pg. 80, Fig. 9; item 10).
- Remove the rotary encoder (S1).
- To mount the rotary encoder (S1), carry out these steps in opposite order.

11.11 Brake resistor (R1) with overtemperature switch



The overtemperature switch at the brake resistor (R1) is not separately available.

- Remove the front panel and the support sheet for electronics (A1) as described in chapters 11.1, 11.2, pg. 81.
- Remove the motor driven lid lock as described in chapter 11.7.1, pg. 84.
- Pull the plug S106 on the electronics (A1), see pg. 95, chapter 12.3.
- Unscrew both fastening screws (pg. 78, Fig. 4, c ; pg. 79, Fig. 8, c) of the brake resistor (pg. 78, Fig. 4, item 31 ; pg. 79, Fig. 8, item 31).
- Remove the brake resistor (R1).
- To mount the brake resistor (R1), carry out these steps in opposite order.

11.12 Temperature sensor (B1) at the bottom of the centrifuge chamber (only in centrifuges with cooling)

- Remove the front panel and the support sheet for electronics (A1) as described in chapters 11.1, 11.2, pg. 81.
- Pull the plug S704 on the electronics (A1), see pg. 95, chapter 12.3.
- Remove all cable fastening elements on the cable of the temperature sensor (B1).
- Dismount the rotor.
- Undo the 4 screws (pg. 78, Fig. 4, a ; pg. 79, Fig. 8, a) on the motor cover and remove the motor cover.
- Remove the rubber packing (pg. 79, Fig. 8, item 13) between the motor cover and the centrifuge chamber.
- Pull out the temperature sensor (pg. 79, Fig. 8, item 39) from the centrifuge chamber.
- Pull the cable of the new temperature sensor through the borehole in the centrifuge chamber and press the temperature sensor (B1) into the borehole.
- To mount the temperature sensor (B1), carry out these steps in opposite order.
- After the installation a compensation of the temperature sensor (B1) must be performed, see pg. 56, chapter 7.14.4.

11.13 Temperature sensor (B3) at the condenser (only in centrifuges with cooling)

- Remove the front panel and the support sheet for electronics (A1) as described in chapters 11.1, 11.2, pg. 81.
- Remove the upper part of the centrifuge housing as described in chapter 11.4.
- Pull the plug S706 on the electronics (A1), see pg. 95, chapter 12.3.
- Remove the temperature sensor (pg. 79, Fig. 6, item 40) at the condenser.
- To mount the temperature sensor (B3), carry out these steps in opposite order. The temperature sensor must be mounted on the condenser at exactly the same position as earlier.
- After the installation a compensation of the temperature sensor (B3) must be performed, see pg. 56, chapter 7.14.4.

11.14 Fan (M3) at the condenser (only in centrifuges with cooling)

- Remove the rear panel.
- Unscrew the two fastening screws (pg. 79, Fig. 8, f) of the fan (pg. 79, Fig. 8, item 41).
- Pull both plugs at the fan.
- Remove the fan.
- To mount the fan (M3), carry out these steps in opposite order.

11.15 Fan (M5) for cooling the electronics (only in centrifuges with cooling)

- Remove the front panel and the support sheet for electronics (A1) as described in chapters 11.1, 11.2, pg. 81.
- Pull the plug S1001 on the electronics (A1), see pg. 95, chapter 12.3.
- Unscrew the three fastening screws (pg. 79, Fig. 7, f) of the fan.
- Remove the fan (pg. 79, Fig. 7, item 42).
- To mount the fan (M5), carry out these steps in opposite order.

11.16 Starting capacitor / starting relay (only in centrifuges with cooling)

- Press the locking mechanism on the left and right at the cover (pg. 79, Fig. 8, g) of the compressor with a screwdriver and remove the cover.
- Exchange of the starting capacitor (pg. 79, Fig. 8, item 37/38):
 - Pull the plugs of the starting capacitor at the starting relay.
 - Loosen the cable fastening elements.
 - Open the fastening clamp (snap-fit) at the starting capacitor and remove the starting capacitor.
 - To mount the starting capacitor, carry out these steps in opposite order.
- Exchange of the starting relay (pg. 79, Fig. 8, item 35/36):
 - Pull all plugs at the starting relay.
 - Pull off the starting relay from the compressor.
 - To mount the starting relay, carry out these steps in opposite order.

11.17 Mains switch (F1)

- Remove the front panel and the support sheet for electronics (A1) as described in chapters 11.1, 11.2, pg. 81.
- Pull the plugs on the mains switch (pg. 78, Fig. 4, item 21/22 ; pg. 79, Fig. 8, item 23/24).
- Press out the mains switch (F1) from the lower part of the centrifuge housing.
- To mount the mains switch (F1), carry out these steps in opposite order.

11.18 Appliance plug (A4 resp. A5)

- Unscrew the two fastening screws of the appliance plug.
- Press out the appliance plug (pg. 78, Fig. 4, item 19/20 ; pg. 79, Fig. 8, item 19/20) from the lower part of the centrifuge housing.
- Pull the plugs on the appliance plug (A4 resp. X1).
- To mount the appliance plug (A4 resp. X1), carry out these steps in opposite order.

11.19 Transformer (T1, only in 120 V version)

- Remove the front panel and the support sheet for electronics (A1) as described in chapters 11.1, 11.2, pg. 81.
- Dismount the rotor.
- Undo the 4 screws (pg. 78, Fig. 4, a ; pg. 79, Fig. 8, a) on the motor cover and remove the motor cover.
- In centrifuges with cooling, remove the rubber packing (pg. 79, Fig. 8, item 13) between the motor cover and the centrifuge chamber.
- Remove the motor as described in chapter 11.5.
- Loosen the cables of the transformer at the terminal block X2 (pg. 78, Fig. 4, d ; pg. 79, Fig. 8, d).
- Unscrew the 2 fastening screws (pg. 78, Fig. 4, e ; pg. 79, Fig. 8, e) of the transformer on the outer part of the housing floor.
- Remove the transformer (pg. 78, Fig. 4, item 23 ; pg. 79, Fig. 8, item 25) through the centrifuge chamber.
- To mount the transformer (T1), carry out these steps in opposite order.

11.20 Circuit breaker (F2, only in 120 V version)

- Remove the front panel and the support sheet for electronics (A1) as described in chapters 11.1, 11.2, pg. 81.
- Pull the plugs on the circuit breaker (pg. 78, Fig. 4, item 26 ; pg. 79, Fig. 8, item 26).
- Press out the circuit breaker (F2) from the lower part of the centrifuge housing.
- To mount the circuit breaker (F2), carry out these steps in opposite order.

11.21 Packing ring

- Open the lid.
- Switch off the mains switch and disconnect the centrifuge from the mains supply.
- Pull out the packing ring (pg. 78, Fig. 3, item 6 ; pg. 79, Fig. 7, item 6) from the gap between the centrifuging chamber and the upper part of the centrifuge housing.
- Completely remove all residual adhesive and residual parts of the sealing ring out from the gap between the centrifugal chamber and the upper part of the centrifuge housing.
- Glue the new packing ring with silicone-free adhesive "Terostat" all around into the gap.
The diameter of the packing ring is slightly larger than the cut-out in the upper part of the housing. Press the packing ring into the gap while compressing it with a piece of cloth.

11.22 Pneumatic spring



The pneumatic springs (pg. 78, Fig. 3, item 5 ; pg. 79, Fig. 7, item 5) may be dismantled only if the lid is open, i.e. if the pneumatic springs are not under tension.

- Open the lid.
- Switch off the mains switch and disconnect the centrifuge from the mains supply.
- Hold the lid with the hand and loosen the stop spring of the connecting pin at the lid.
- Press the opened lid slightly to the back in order to relieve the connecting pin and take out the connecting pin.
- Unhinge the piston rod (Fig. 17, a) of the pneumatic spring, see Fig. 17.
- Remove the pneumatic spring.
- To mount the pneumatic spring, carry out these steps in opposite order.



The hinging of the piston rod (Fig. 17, a) is easier to handle if the 5 screws (pg. 78, Fig. 3, e ; pg. 79, Fig. 7, e) of the lid inner cover are loosened a little bit before. The lid can then be opened a bit further.

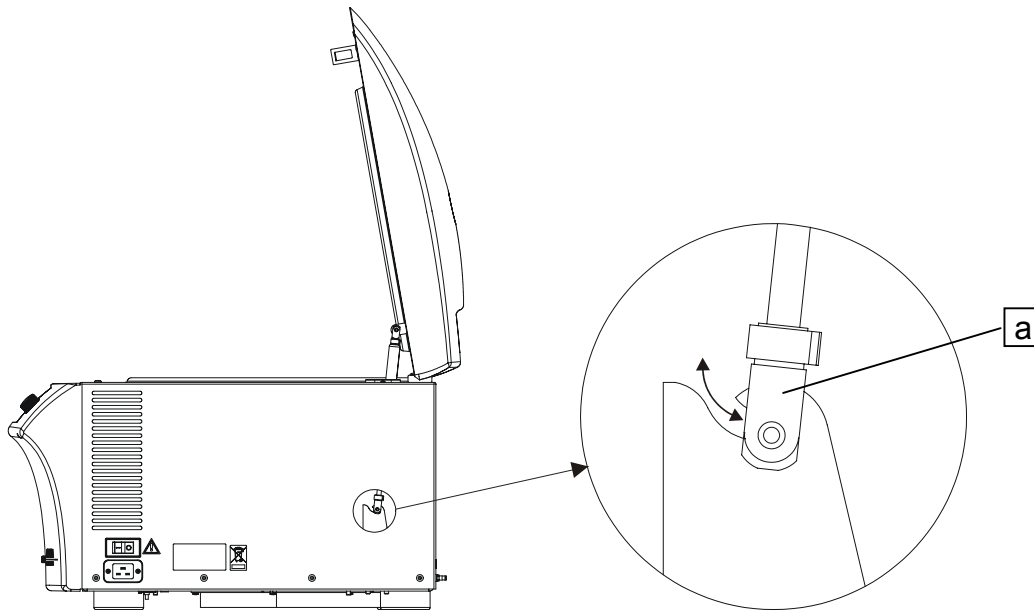
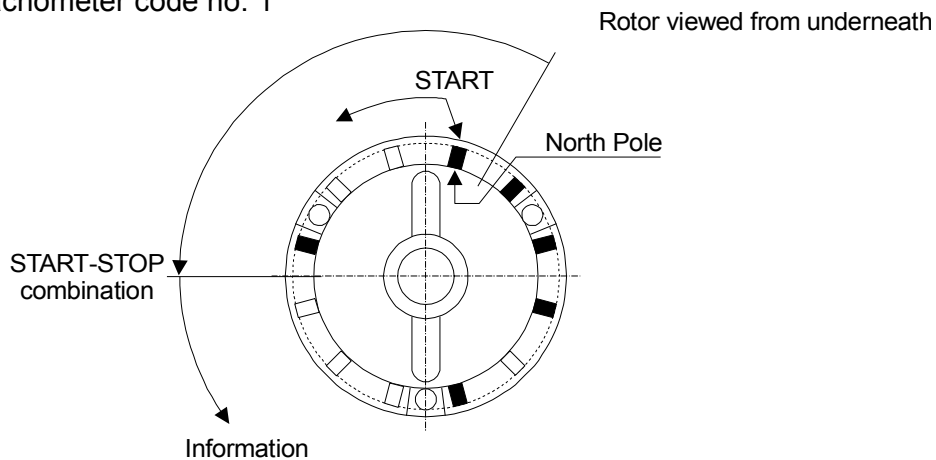

Fig. 17

12 Technical documents

12.1 Tachometer code configuration of the rotors

Example: tachometer code no. 1



tachometer code determines:

1. maximum speed of rotor
2. run up and braking ramps
3. control response of electronics

e.g. Rotor 1726

1001,00010111

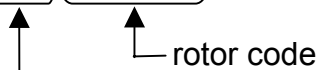

rotor code

Start / Stop combination.

The begin of the Start / Stop combination is

marked with a white dot.

0 = no magnet (empty place), 1 = magnet inserted

Tachometer code-no.	Configuration	RPM	Rotor
0	1001 00001111	500	---
1	1001 00010111	4000	1713, 1725, 1726, 1748, 1794
2	1001 00011011	4000	1717, 1724
3	1001 00011101	10000 / 11000*	1720, 1792
4	1001 00011110	500	---
5	1001 01000111	500	---
6	1001 01010101	15000	1789
7	1001 01010110	4000	1798
8	1001 01011010	5000	1754
9	1001 01100011	4000	1760
10	1001 01110001	15700	---
11	1001 10000111	4500	1721
12	1001 10001011	15000	1711
13	1001 10001101	14000	1797*
14	1001 10100011	500	---
15	1001 11000011	500	---

* only with ROTINA 380 R

12.2 Cooling diagram

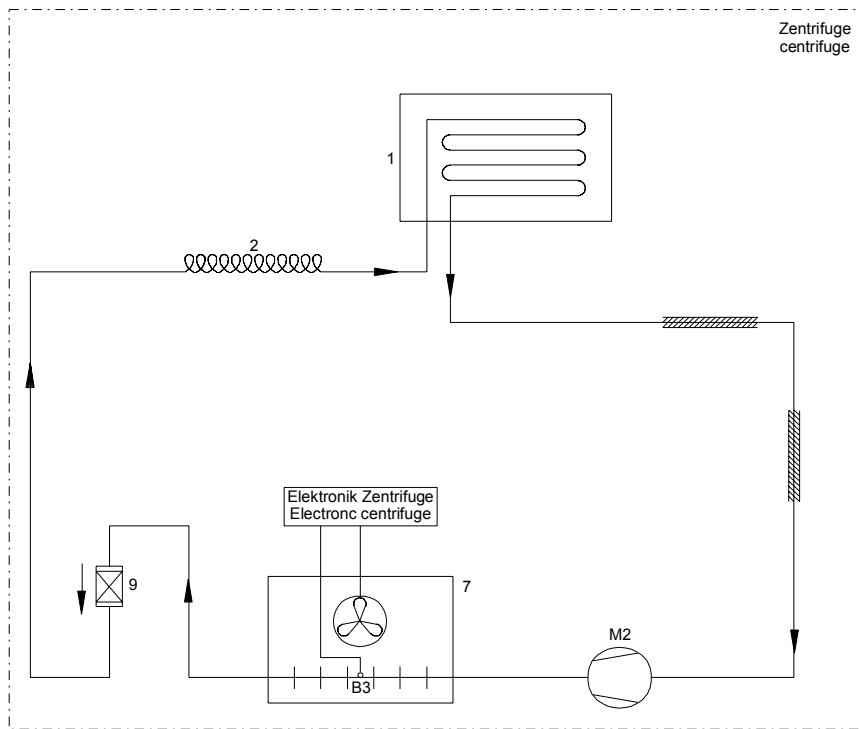

1	Evaporator (centrifuge chamber)
2	Capillary tube
7	Air-cooled condenser
9	Filter dryer (flow direction vertical from top to bottom !!!)
B3	Temperature sensor on condenser (controlled by centrifuge electronics)
M2	Compressor

- BLANK PAGE -

12.3 Connecting diagram

12.3.1 Abbreviations of the cable colours

Abbreviation	Colour
BK	black
BN	brown
BU	blue
GD	gold
GN	green
GNYE	green-yellow
GY	grey
OG	orange
PK	pink
RD	red
SR	silver
TQ	turquoise
Transp.	transparent
VT	violet
WH	white
YE	yellow

12.3.2 Connecting diagram ROTINA 380 / 380 R

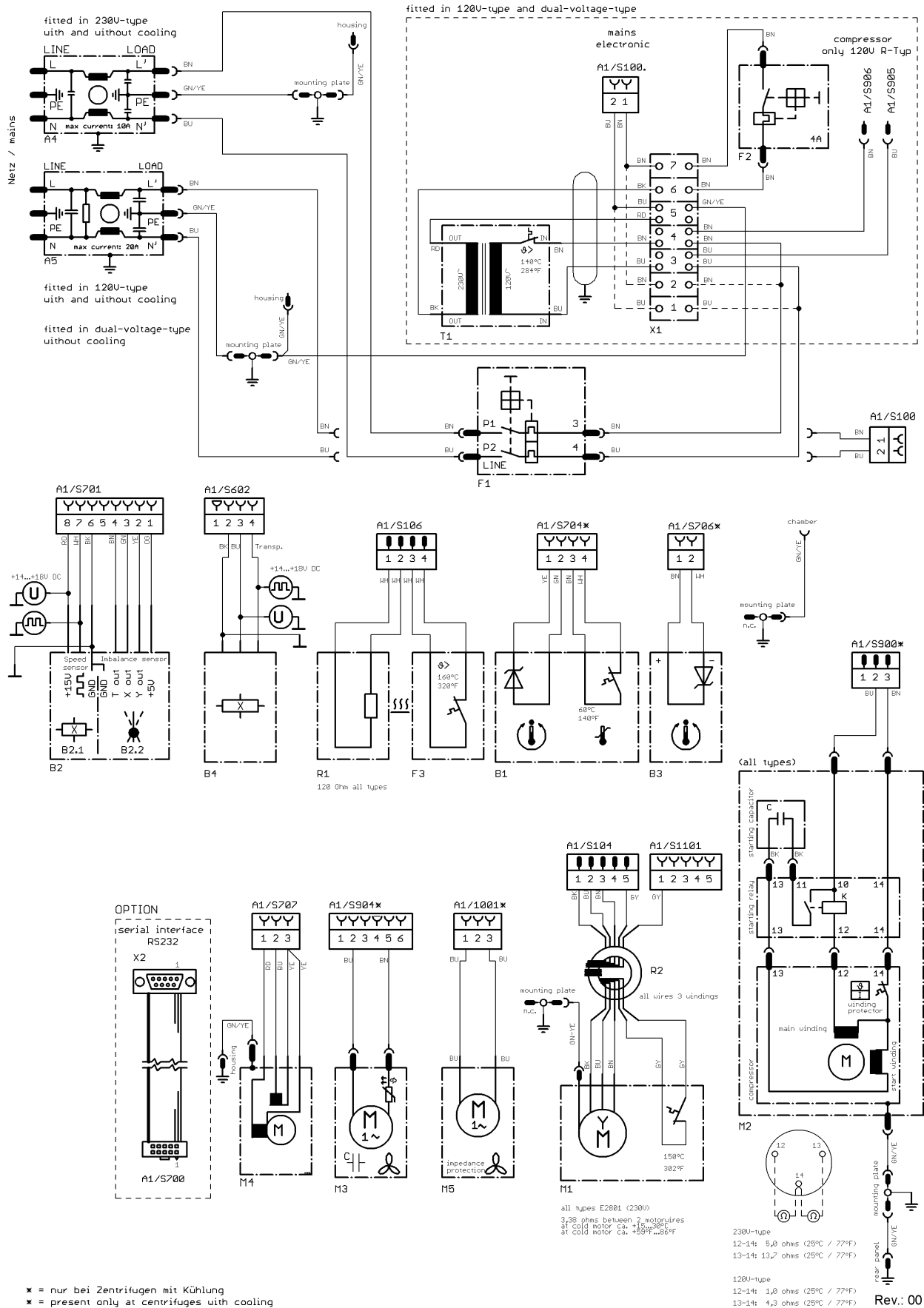

* = nur bei Zentrifugen mit Kühlung
 * = present only at centrifuges with cooling

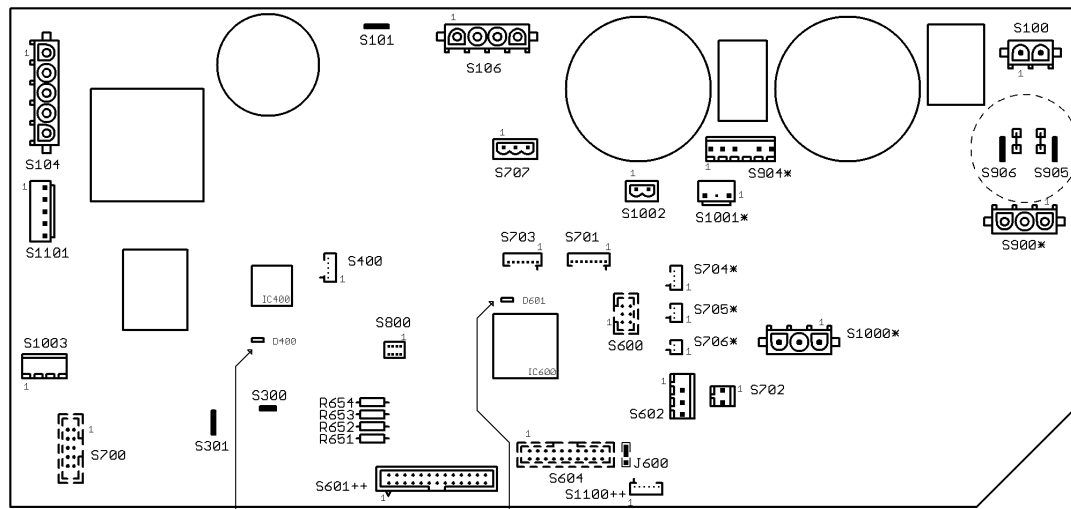
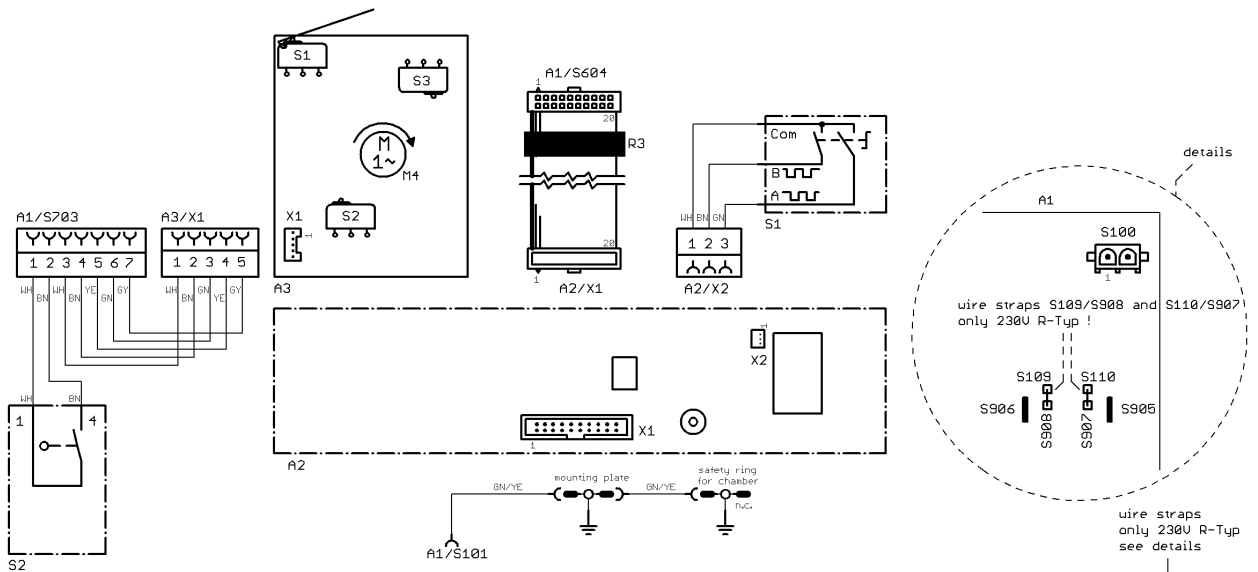

A1 status LED frequency converter
 status LED control processor
 --- ak
 - - - - error
 ++ = nur bei Zentrifugen mit Rotor-Positionierung
 ++ = present only at centrifuges with rotor positioning
 * = nur bei Zentrifugen mit Kühlung
 * = present only at centrifuges with cooling

A1	Elektronik ROTINA 300 / 380R	electronic ROTINA 300 / 380R
A2	Bedienteil	operating panel
A3	motorischer Deckelverschluss	motor driven lid locking
A4	Gerätestecker mit Funkentstörfilter max. 10A	appliance plug with radio interference suppression filter
A5	Gerätestecker mit Funkentstörfilter max. 20A	appliance plug with radio interference suppression filter
B1	Temperaturfühler / Temperaturschutz am Kesselboden	temperature sensor / overheating protection at chamber bottom in centrifuge chamber
B2	Drehzahlsensor B2.1 / Unwuchtsensor B2.2	speed sensor B2.1 / imbalance sensor B2.2
B3	Temperaturfühler am Kondensator	temperature sensor at condenser
B4	Drehzahlsensor / Rotorerkennung	speed sensor / rotor identification
F1	Geräteschutzschalter	unit protection switch
F2	Schutzschalter	protection switch
F3	Übertemperaturschutz am Bremswiderstand	overheating protection for braking resistor
M1	Motor der Zentrifuge	motor of centrifuge
M2	Verdichter	cooling compressor
M3	Lüfter am Kondensator	fan at condenser
M4	Antriebsmotor des motorischen Deckelverschlusses	driving motor of motor driven lid locking
M5	Lüfter für Elektronik ROTINA 380R	fan for electronic ROTINA 380R
R1	Bremswiderstand	braking resistor
R2	Entstördrossel Motor	interference coil
R3	Entstör- Ferrit Bedienteil	interference ferrit
S1	Drehimpulsgeber	rotary encoder
S2	Mikroschalter am linken Verschluss	micro switch at left lid lock
T1	Transformator mit Thermoschalter	Transformer with overheating protection
X1	Klemmenleiste 7polig	terminal block
X2	RS232-Schnittstelle (Option)	serial interface RS232 (optional)

Rev.: 00

12.4 Technical specifications

Manufacturer	Andreas Hettich GmbH & Co. KG D-78532 Tuttlingen				
Model	ROTINA 380			ROTINA 380 R	
Type	1701-30	1701	1701-01	1706	1706-01
Mains voltage ($\pm 10\%$)	200-240 V 1~ / 100-127 V 1~	200-240 V 1~	100-127 V 1~	200-240 V 1~	110-127V 1~
Mains frequency	50 – 60 Hz	50 – 60 Hz	50 – 60 Hz	50 Hz	60 Hz
Connected load	max. 450 VA	650 VA	700 VA	1300 VA	1400 VA
Current consumption		3.3 A	7.0 A	6.0 A	13.0 A
Cooling medium	----			R 404A	
Max. capacity	4 x 290 ml				
Allowed density	1.2 kg/dm ³				
Speed (RPM)	4000	15000			
Force (RCF)	3095	24400			
Kinetic energy	6200 Nm	18500 Nm		35000 Nm	
Obligatory inspection (BGR 261)	no	yes			
Ambient conditions (EN 61010-1)	<p>Indoors only</p> <p>Up to 2000 m above sea level</p> <p>2°C to 35°C 5°C to 35°C</p> <p>Maximum relative humidity 80% for temperatures up to 31°C, linearly decreasing to 50% relative humidity at 40°C.</p>				
– Set-up site					
– Altitude					
– Ambient temperature					
– Humidity					
– Excess-voltage category (IEC 60364-4-443)	II				
– Pollution degree	2				
Device protection class	I				
Not suitable for use in explosion-endangered areas.					
EMC					
– Emitted interference (suppression of radio interference)	EN 55011, Group 1, Class B EN 61000-3-2 EN 61000-3-3 FCC Class B	EN 55011, Group 1, Class B EN 61000-3-2 EN 61000-3-3	FCC Class B	EN 55011, Group 1, Class B EN 61000-3-2 EN 61000-3-3	FCC Class B
– Interference immunity	EN 61000-6-2	EN 61000-6-2	----	EN 61000-6-2	----
Noise level (dependent on rotor)	≤ 63 dB(A)			≤ 60 dB(A)	
Dimensions					
– Width	457 mm			457 mm	
– Depth	600 mm			750 mm	
– Height	418 mm			418 mm	
Weight	approx. 58.5 kg	approx. 51 kg	approx. 58.5 kg	approx. 78 kg	approx. 85.5 kg